

# LONCIN LC1P88F-1 SERVICE MANUAL



## Quick Links

[Engine Structure](#)

[Product Technical Parameters](#)

[Diagram of Electrical Wiring](#)

[Engine Oil](#)

[Carburetor](#)

# Table of Contents

Table of Contents

Engine Structure

Product Technical Parameters

Drawings of Mounting Dimensions

Drawings of P.T.O Dimensions

Diagram of Electrical Wiring

Precautions for Maintenance

Serial Number Location

Maintenance Standard

Fastener Torque Specification

Maintenance Schedule

Engine Oil

Air Cleaner

Spark Plug

Valve Clearance

Carburetor

Governor

Oil Filter Replacement

Muffler

Hard Starting

Low Power

Speed Unstable

Exhaust Color Abnormal

Engine Liable to Stall

Engine Speed Does Not Increase

Engine Overheating

Engine's Abnormal Sound

Electric Starting System Failure

Cylinder Compression Check

Spark Plug Check

Precautions for Disassembly

Disassembly

Reassembly

Disassembly and Service of Engine

Air Cleaner

Cooling Fan, Fan Cover

Governor System

Carburetor

Flywheel, Ignition Coil, Starter Motor

Cylinder Head, Valves

Crankcase Cover, Governor Gear

Crankcase, Crankshaft, Piston

Other ManualsLib Projects



LC1P88F-1 • LC1P90F-1

LC1P92F-1

# SERVICE MANUAL



LONCIN MOTOR CO., LTD.

# SAFETY PRECAUTIONS

---

Thoroughly read this MANUAL before operating and servicing the generator set. Safe operation and top performance can only be attained when equipment is operated and maintained properly.

The following symbols, found throughout this manual, alert you to potentially dangerous conditions to operators, service personnel and equipment.

**⚠ DANGER** *This symbol alerts you to an immediate hazard that will result in severe personal injury or death.*

**⚠ WARNING** *This symbol alerts you to a hazard or unsafe practice that can result in severe personal injury or death.*

**⚠ CAUTION** *This symbol alerts you to a hazard or unsafe practice that can result in personal injury or damage to property.*

Fuel, exhaust, and moving parts present hazards against which precautions must be taken to prevent severe personal injury or death.

## Be Careful when Fueling

- As gasoline is flammable, fueling the engine must be performed in a well-ventilated outdoor place after the engine is stopped.
- No smoking is allowed during fueling, keep flames and sparks away.
- Never start the engine before the place with spilled gasoline has not dried.

## Hot Exhaust

- Muffler temperature is very high during engine's running, and even remains hot after engine has been stopped for a while. Be careful not to touch a hot muffler. Stop the engine indoors, then cool the engine indoors, and start maintenance after cooling.
- In order to avoid fire, the engine shall be kept at least 1m from any wall or any other equipment when it is working. Flammables shall all the more be kept far away from the engine.

## Carbon Monoxide

- The exhaust contains poisonous carbon monoxide. Avoid inhale the exhaust.
- Never run the engine indoors.
- Never run the engine in a closed garage or any other closed space.

## General Precautions

- Thoroughly read this MANUAL, get familiar with all the operating mechanisms and the correct methods for using and maintaining the engine, and master the operation method for stopping the engine and quickly declutching.
- Don't operate the engine when you are tired, sick or have drunk any alcoholic beverage, or you may be seriously injured.

# SAFETY PRECAUTIONS

---

- Children, persons who haven't read this Manual, or haven't be trained are prohibited from using the engine.
- Never repair the machine at will without mastering the method for repairing the engine.
- Don't modify the machine or change its structure at will; once the machine loses balance, it is very likely to cause damage or injury accidents.

# CONTENTS

---

## SECTION 1 Parameters

1-1 Engine Structure .....	1
1-2 Product Technical Parameters .....	2
1-3 Drawings of Mounting Dimensions .....	3
1-4 Drawings of P.T.O Dimensions .....	4
1-5 Diagram of Electrical Wiring .....	5

## SECTION 2 SERVICE INFORMATION

2-1 Precautions for Maintenance .....	6
2-2 Serial Number Location .....	7
2-3 Maintenance Standard .....	8
2-4 Fastener Torque Specification .....	10

## SECTION 3 MAINTENANCE

3-1 Maintenance Schedule .....	11
3-2 Engine Oil .....	12
3-3 Air Cleaner .....	12
3-4 Spark Plug .....	14
3-5 Valve Clearance .....	14
3-6 Carburetor .....	15
3-7 Governor .....	15
3-8 Oil Filter Replacement .....	16
3-9 Muffler .....	16

## SECTION 4 Troubleshooting

4-1 Hard Starting .....	17
4-2 Low Power .....	18
4-3 Speed Unstable .....	19
4-4 Exhaust Color Abnormal .....	20
4-5 Engine Liable to Stall .....	21
4-6 Engine Speed Does Not Increase .....	21
4-7 Engine Overheating .....	22
4-8 Engine's Abnormal Sound .....	23
4-9 Electric Starting System Failure .....	24

# CONTENTS

---

4-10 Cylinder Compression Check .....	25
4-11 Spark Plug Check .....	25
<b>SECTION 5 Disassembly and Service</b>	
5-1 Precautions for Disassembly .....	26
5-1-1 Disassembly .....	26
5-1-2 Reassembly .....	26
5-2 Disassembly and Service of Engine .....	27
5-2-1 Air Cleaner .....	27
5-2-2 Cooling Fan, Fan Cover .....	28
5-2-3 Governor System .....	29
5-2-4 Carburetor .....	30
5-2-5 Flywheel, Ignition Coil, Starter Motor .....	32
5-2-6 Cylinder Head, Valves .....	34
5-2-7 Crankcase Cover, Governor Gear .....	41
5-2-8 Crankcase, Crankshaft, Piston .....	42

# SECTION 1 Parameters

---

## 1-1 Engine Structure

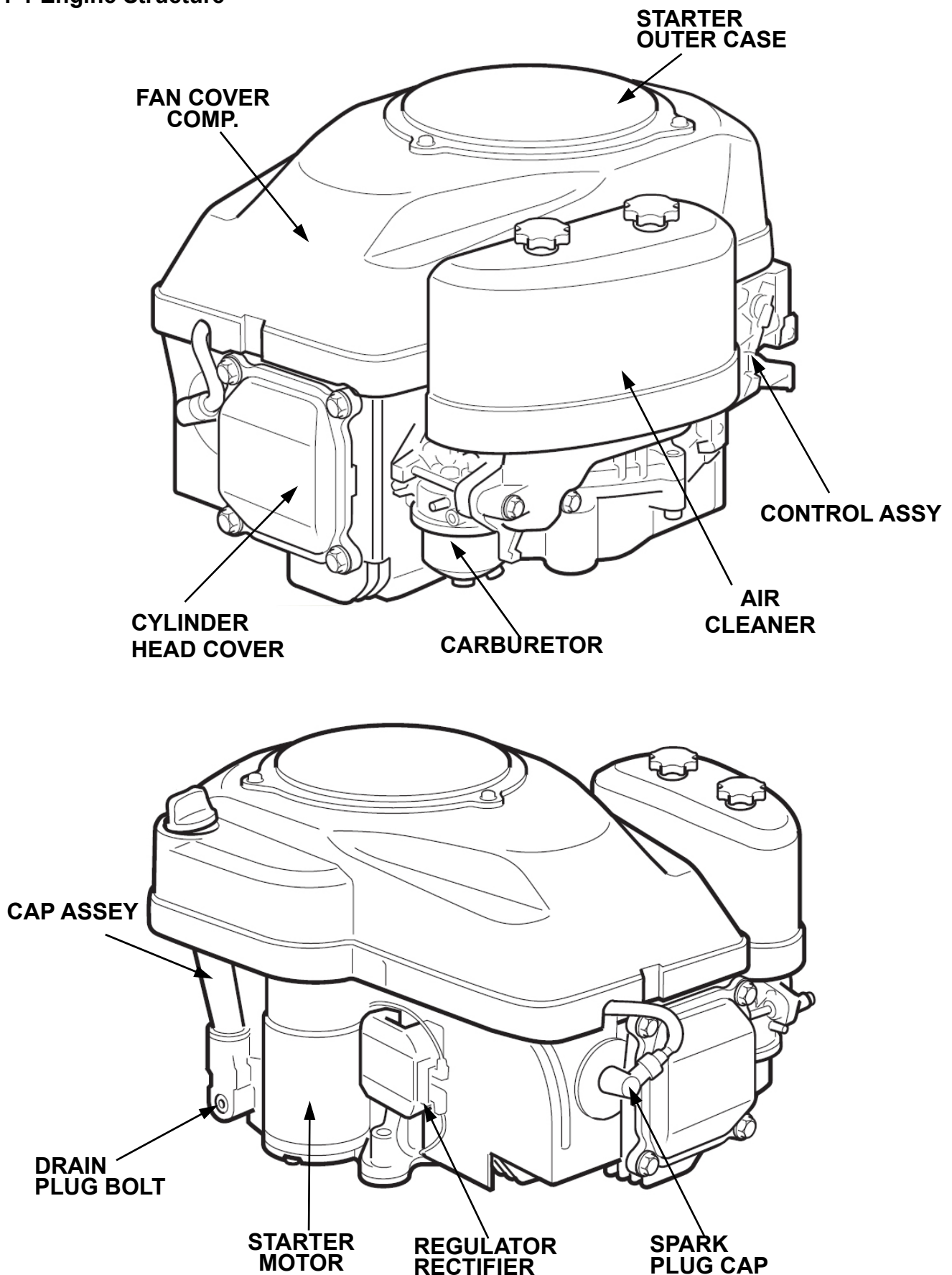

# SECTION 1 Parameters

## 1-2 Product Technical Parameters

Model	LC1P88F-1	LC1P90F-1	LC1P92F-1
Type	Single cylinder, 4-Stroke, Forced Air Cooling, OHV		
Displacement(cc)	413	432	452
Cylinder bore × Stroke(mm)	88×68	90×68	92×68
Net power (KW/3600rpm)	8.6	8.8	9.2
Net torque (N·m/rpm)	24 /2600	26 /2600	28/2600
Idle speed ( r/min )	1850±150		
Compression ratio	8.7 : 1		
Output rotation	Counter clockwise (from P.T.O. side)		
Noise (≤7m)	/	/	/
Igniting mode	Transistorized magneto Ignition		
Starting mode	Electric		
Carburetor	Horizontal, butterfly valve		
Lubricating mode	Splash lubrication		
Governor	Centrifugal mass type		
Air cleaner	Semi dry, dual element		
Engine oil capacity	1.2L	1.2L	1.2L
Fuel tank capacity	/	/	/
Net weight (kg)	31	31	31
Dimensions (L×W×H)(mm)	432×388×300	432×388×300	432×388×300

# SECTION 1 Parameters

## 1-3 Drawings of Mounting Dimensions

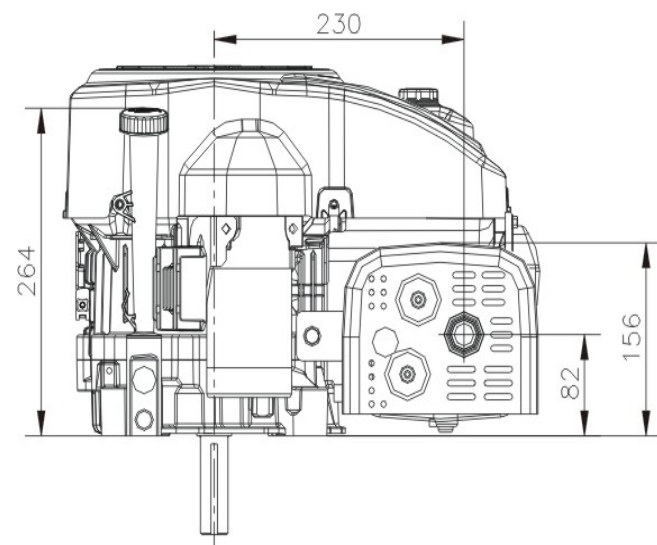
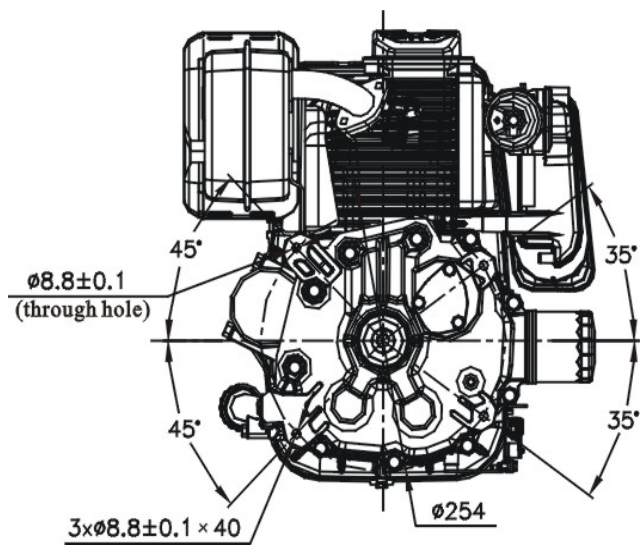
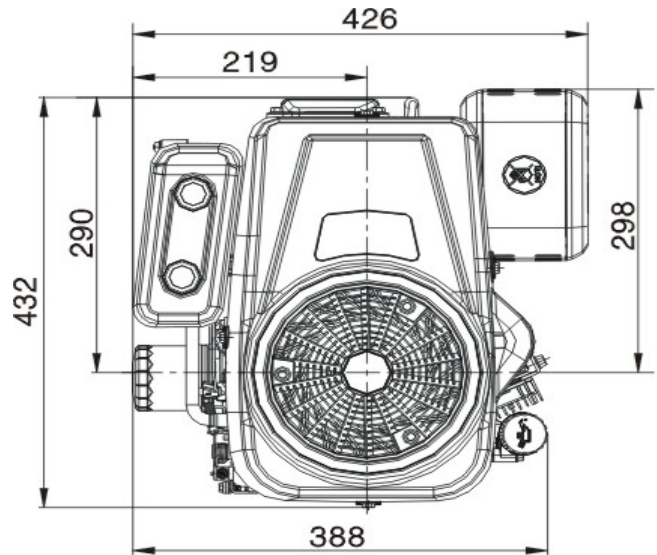
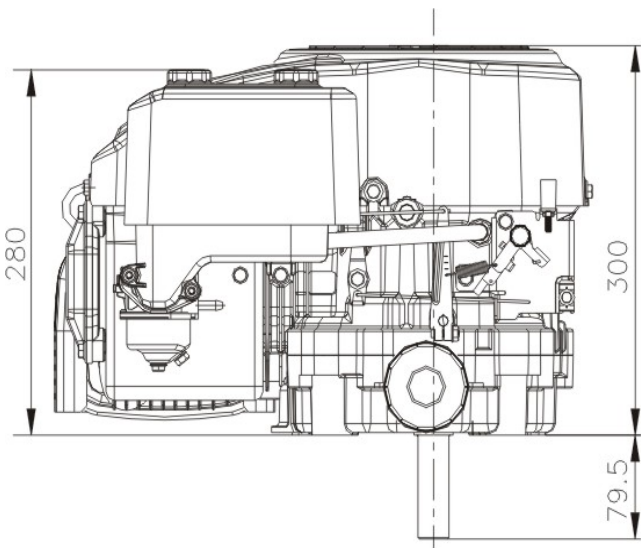

# SECTION 1 Parameters

## 1-4 Drawings of P.T.O Dimensions

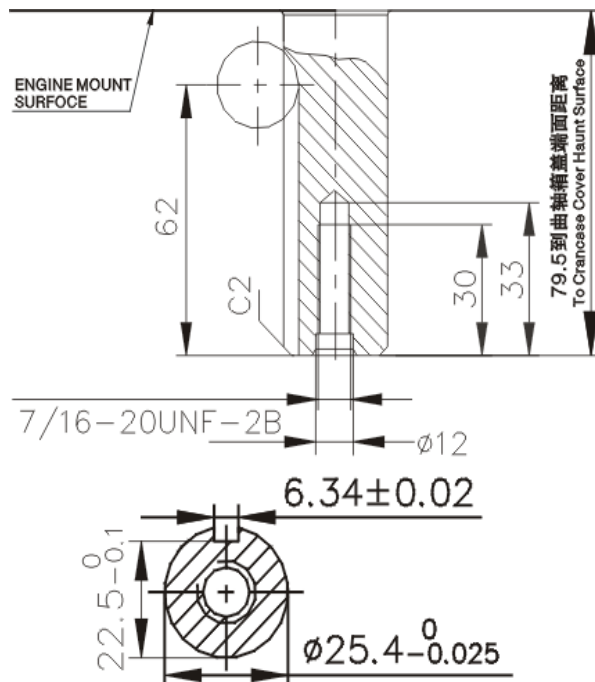

Shaft A/Type A

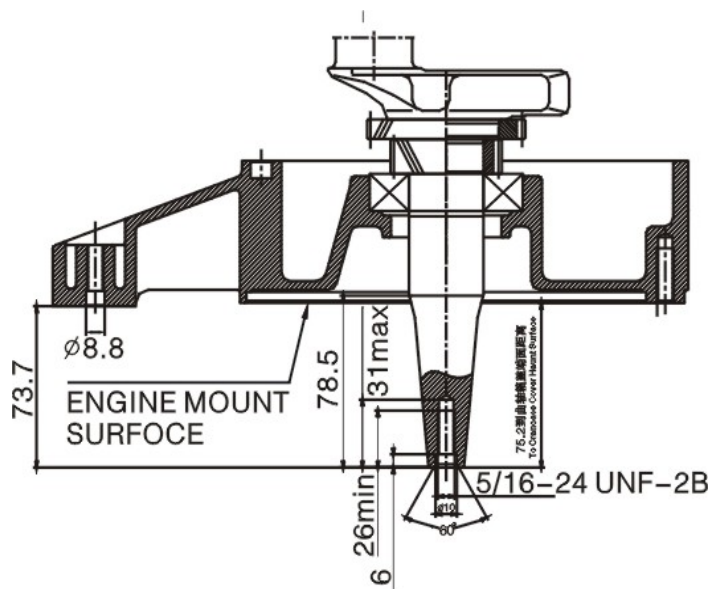

Shaft B /Type B

# SECTION 1 Parameters

## 1-5 Diagram of Electrical Wiring

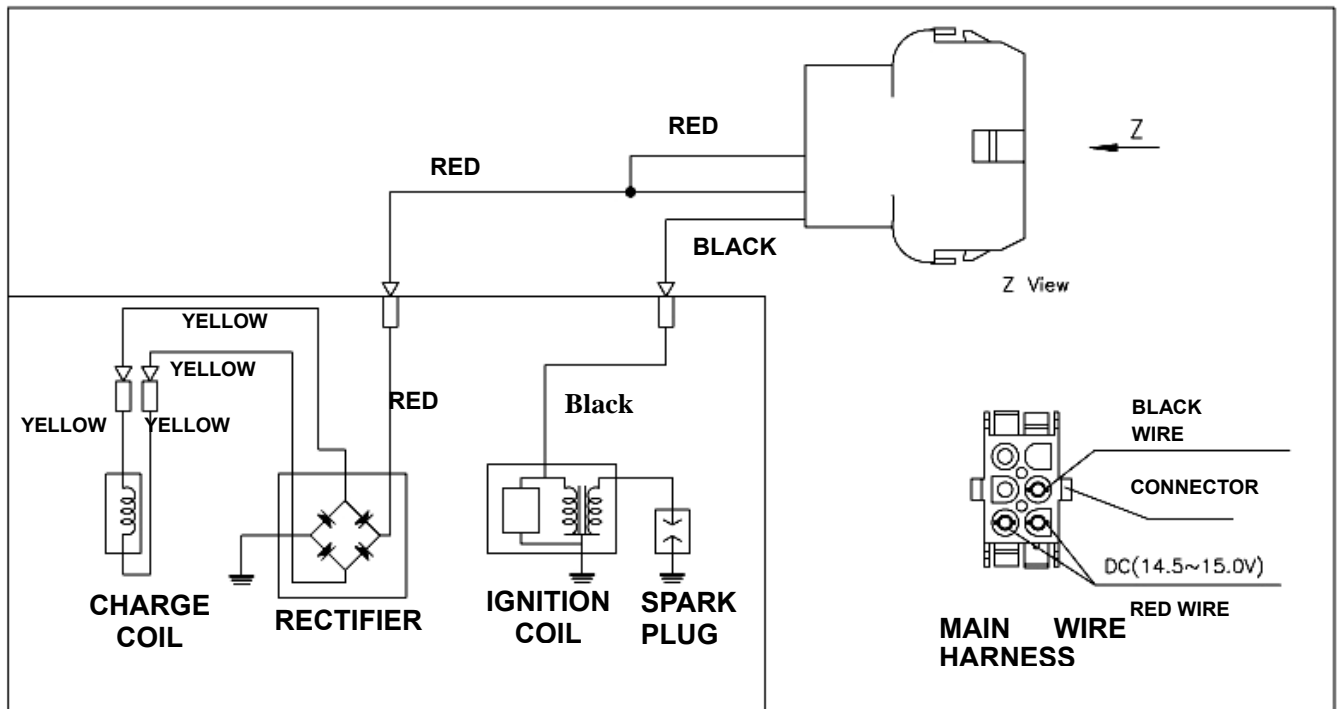

# SECTION 2 SERVICE INFORMATION

## 2-1 Precautions for Maintenance

1. Parts, oil and grease must be genuine LONCIN products or products designated by LONCIN. Parts not meeting LONCIN's design specifications may damage the device or engine.

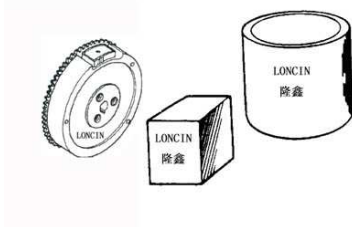

2. Work to be done with special tools must be done with such tools and corresponding devices.

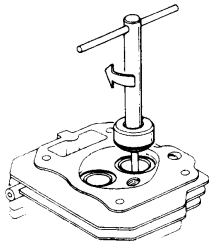

3. Gaskets, washers, O-rings and oil seals must be replaced after disassembly.

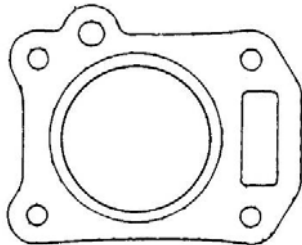

4. When screwing bolts, nuts or screws, tighten from the ones of larger diameters and on inner side to the ones of smaller diameters and on the outer side, and tighten in a crisscross pattern to the specified torque diagonally.

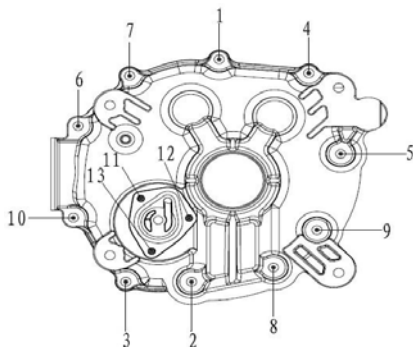

5. Clean parts in cleaning solvent upon disassembly. Lubricate any sliding surfaces before reassembly.

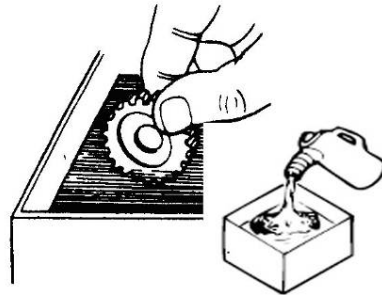

6. After reassembly, check all parts for proper installation and operation.

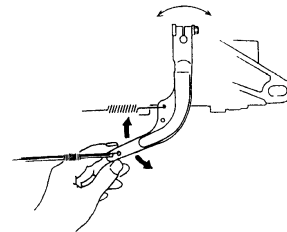

7. Don't maintain unless the engine is stopped and has cooled, otherwise, burn can happen when engine is hot.

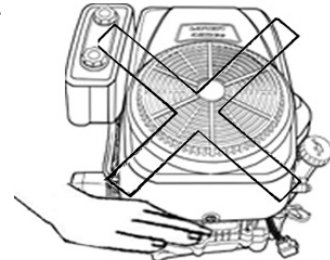

8. If you want to perform a test run of the engine in the work area after maintenance, take care to ensure adequate ventilation in the area, and never smoke or light a fire near fuel, grease or other inflammable materials.

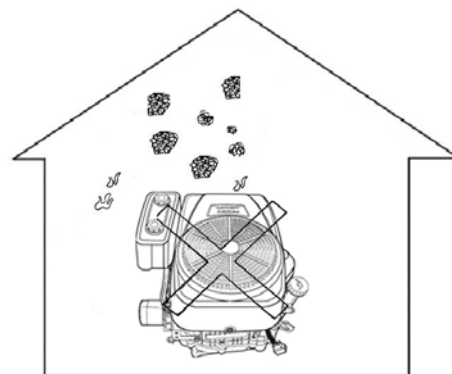

# SECTION 2 SERVICE INFORMATION

---

## 2-2 Serial Number Location

The engine's serial number is stamped on the crankcase as shown below. You will need this information for inquiring about the engine or for ordering parts when a device under the warranty of Loncin's dealer needs correct parts.

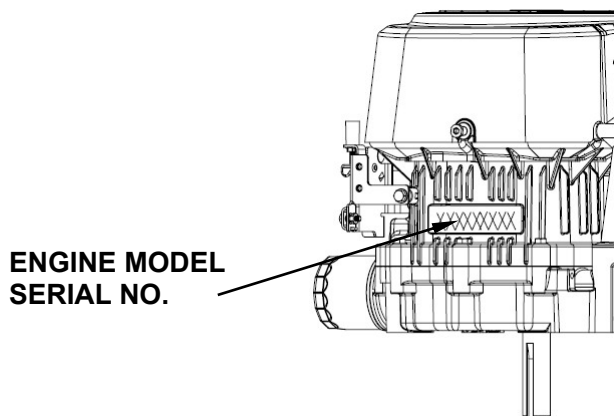

Engine model and serial No:

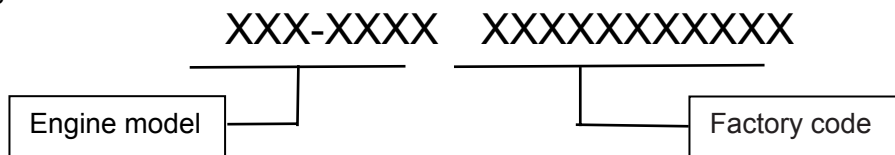

**Note: The first 5 digits in factory code mean date of manufacture.**

# SECTION 2 SERVICE INFORMATION

## 2-3 Maintenance Standard

Unspecified unit: mm

Part	Item	1P88F-1		1P90F-1	
		Standard	Service limit	Standard	Service limit
Engine	Idle speed	1850±150	—	1850±150	—
	Compression pressure(kg/cm <sup>2</sup> ) *	8.1	—	8.2	—
Cylinder head	Warpage	—	0.10	—	0.10
Cylinder	Sleeve (I.D. r X)	88~88.01	88.1	90~90.01	90.1
	Sleeve (I.D. r Y)	88~88.01	88.1	90~90.01	90.1
Piston	Skirt O.D.	87.965~87.975	87.94	89.965~89.975	89.94
	Clearance to cylinder	0.025~0.045	0.055	0.025~0.045	0.055
	Piston pin bore I.D.	20.002~20.008	20.01	20.002~20.008	20.01
	Piston pin-to-piston pin bore clearance	0.004~0.016	0.029	0.004~0.016	0.029
Piston pin	Outside diameter	19.992~19.998	19.9	19.992~19.998	19.9
Piston ring	Ring side clearance (Top/Second)	0.02~0.06	0.11	0.02~0.06	0.11
	Ring end gap (Top/Second)	0.15~0.30 / 0.25~0.40	1.0	0.15~0.30 / 0.25~0.40	1.0
	Ring width (Top/Second)	1.17~1.19 / 1.47~1.49	1.1/1.4	1.17~1.19 / 1.47~1.49	1.1/1.4
	Ring width (Oil ring)	2.68~2.78	2.5	2.68~2.78	2.5
Connecting rod	Small end I.D.	20.007~20.018	20.02	20.007~20.018	20.02
	Big end I.D.	36.015~36.025	36.03	36.015~36.025	36.03
	Big end side clearance	0.02~0.35	0.4	0.02~0.35	0.4
Crankshaft	Crankpin O.D.	35.966~35.981	35.946	35.966~35.981	35.946
Valve	Clearance(cold) (IN)	0.10±0.02	—	0.10±0.02	—
	Clearance(cold) (EX)	0.15±0.02	—	0.15±0.02	—
	Stem O.D. (IN)	6.565~6.58	6.550	6.565~6.58	6.550
	Stem O.D. (EX)	6.545~6.56	6.530	6.545~6.56	6.530
Valve guide	I.D. (IN,EX)	6.6~6.615	6.7	6.6~6.615	6.7
	Stem-to-guide clearance (IN)	0.02~0.05	0.12	0.02~0.05	0.12
	Stem-to-guide clearance (EX)	0.04~0.07	0.17	0.04~0.07	0.17
Valve seat	Seat width	0.8~1	1.5	0.8~1	1.5
Valve spring	Free length	39.5~40.5	39	39.5~40.5	39
Camshaft	Cam height (IN)	32.563~32.603	32.4	32.563~32.603	32.4
	Cam height (EX)	32.049~32.099	31.9	32.049~32.099	31.9
	O.D. (bearing section)	15.966~15.984	15.916	15.966~15.984	15.916
Crankcase cover	Camshaft holder I.D.	16~16.018	16.1	16~16.018	16.1
	Crankshaft holder I.D.	71.949~71.979	72.05	71.949~71.979	72.05
Spark plug	Gap	0.7-0.8	—	0.7-0.8	—
Ignition coil	Resistance (primary)	1.0-1.4Ω	—	1.0-1.4Ω	—
	Resistance (secondary)	5.2-6.4KΩ	—	5.2-6.4KΩ	—
	Air gap (at flywheel)	0.4±0.1	—	0.4±0.1	—

# SECTION 2 SERVICE INFORMATION

Part	Item	1P92F-1	
		标准	标准
Engine	Idle speed	1800±100	—
	Compression pressure(kg/cm2) *	8.8	8.8
Cylinder head	Warpage	—	0.10
Cylinder	Sleeve (I.D. r X)	92~92.01	92.1
	Sleeve (I.D. r Y)	92~92.01	92.1
Piston	Skirt O.D.	91.96~91.975	91.94
	Clearance to cylinder	0.025~0.045	0.055
	Piston pin bore I.D.	20.002~20.008	20.01
	Piston-to-piston pin clearance	0.004~0.016	0.029
Piston pin	O.D.	19.992~19.998	19.9
Piston ring	Ring side clearance (Top/Second)	0.02~0.06	0.11
	Ring end gap (Top/Second)	0.15~0.30 / 0.25~0.40	1.0
	Ring width (Top/Second)	1.17~1.19 / 1.47~1.49	1.1/1.4
	Ring width (Oil ring)	2.68~2.78	2.5
Connecting rod	Small end I.D.	20.007~20.018	20.02
	Big end I.D.	36.015~36.025	36.03
	Big end side clearance	0.02~0.35	0.4
Crankshaft	Crankpin O.D.	35.966~35.981	35.946
Valve	Clearance(cold) (IN)	0.10±0.02	—
	Clearance(cold) (EX)	0.15±0.02	—
	Stem O.D. (IN)	6.565~6.58	6.550
	Stem O.D. (EX)	6.545~6.56	6.530
Valve guide	I.D. (IN,EX)	6.6~6.615	6.7
	Stem-to-guide clearance (IN)	0.02~0.05	0.015
	Stem-to-guide clearance (EX)	0.04~0.07	0.17
Valve seat	Seat width	0.8~1	1.5
Valve spring	Free length	39.5~40.5	39
Camshaft	Cam height (IN)	32.563~32.603	32.4
	Cam height (EX)	32.049~32.099	31.9
	O.D. (bearing section)	15.966~15.984	15.916
Crankcase cover	Camshaft hole I.D.	16~16.018	16.1
	Crankshaft holder I.D.	71.949~71.979	72.05
Spark plug	Gap	0.7-0.8	—
Ignition coil	Resistance (primary)	1.0-1.4Ω	—
	Resistance (secondary)	5.2-6.4KΩ	—
	Air gap (at flywheel)	0.4±0.1	0.4±0.1

- Value at the speed 1850rpm of the engine.

# SECTION 2 SERVICE INFORMATION

---

## 2-4 Fastener Torque Specification

### (1) Torque Specification

Item	Thread specification	Torque range(N.m)
Connecting rod bolt	M8×1	16-18
Cylinder head bolt	M10×1.25	50-55
Flywheel mounting nut	M16×1.5	90-115
Crankcase cover bolt	M8×1	24-28
Oil drain bolt (in crankcase)	M16×1.5	18-23
Air cleaner mounting nut	M6×1	6-10
Pivot adjusting nut	M6×0.5	12-16
Pivot bolt	M8×1.25	22-26
Governor arm nut	M6×1.0	9-13
Starter motor fastening bolt	M8×1.25	27-30
Spark plug		27-30

Note: Refer to standard torque specification for bolts and nuts not specified in the table above.

### (2) Standard Torques Specification

Faster	Thread specification	Torque range (N.m)
Bolt, nut	5mm bolt, nut	4-7
	6mm bolt, nut	8-12
	8mm bolt, nut	20-28
	10mm bolt, nut	35-40
	12mm bolt, nut	50-60

# SECTION 3 MAINTENANCE

## 3-1 Maintenance schedule

Maintenance schedule		Each Use	First month or 5 hours	1 or 25 hours	3 or 50 hours	6 or 100 hours	Every year or 200 hours	2 or 200 hours
Engine oil	Oil level	•						
	replace		•			•		
Air cleaner element	Check	•						
	Clean			•(1)				
	replace					•(1)		
Oil Filter	replace					•(2)		
Fuel filter	replace					•		
Spark plug	Clean-adjust					•		
	Replace						•	
Valve clearance	Check-adjust					•(2)		
Combustion chamber	clean						•(2)	
Fuel tube	replace	Each 2 years (Replace if necessary) (2)						

(1) Service more frequently when used in the dust areas.

(2) These items are to be maintained by designated dealers unless the user has special tools and skills for maintenance.

# SECTION 3 MAINTENANCE

## 3-2 Engine Oil

**Note: Drain the oil while the engine is stopped yet warm to ensure rapid and complete draining.**

1. Clean the area around the oil filler /cap/dipstick and oil drain bolt.

Remove the oil filler cap/dipstick.

2. Drain the engine oil into a suitable container using one of the following methods.

### Oil drain bolt method:

a. Remove the oil drain bolt and seal washer, drain the oil into a suitable container.

b. After draining, install the drain bolt and tighten it securely.

### Oil filler tube method:

In certain applications, it may be possible to drain the engine oil from the oil filler tube.

a. Turn the fuel valve to the OFF position.

b. Remove the oil filler cap/dipstick.

c. Tip the engine (air cleaner side up ) and drain the oil through the oil filler tube into a suitable container.

3. Refill the engine with the correct amount of the recommended oil.

### Engine oil capacity: 1 L

Use a high-detergent, premium quality 4-stroke engine oil certified to meet or exceed US. Automobile manufacturers' requirements for API Service Classification SG, and SF.

SAE 15W-40 is recommended for general, all-temperature use. Other viscosities shown in the chart may be used when the average temperature in your area is within the indicated range.

4. Insert the oil filler cap/dipstick into the oil filler tube. Remove the oil filler cap/dipstick and check the oil level on it. Add oil until the level reaches the upper mark on the dipstick. After running the engine, recheck the oil level and adjust if necessary.

Wash your hands thoroughly with soap and water as soon as possible after contact with used oil which contains carcinogenic substances.

UPPER  
LIMIT  
  
LOWER  
LIMIT

OIL FILLER  
CAP/DIPSTICK

OIL DRAIN  
BOLT

OIL FILLER  
CAP/DIP STICK

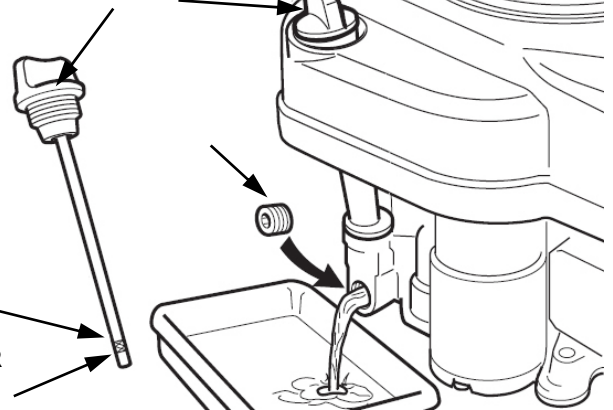

Please dispose of used motor oil and the oil containers in a manner that is friendly to the environment. We suggest you put it in a sealed container and take it to your local recycling center or service station for reclamation. Do not throw it in the trash, or pour it on the ground.

# SECTION 3 MAINTENANCE

## 3-3 Air Cleaner

1. Remove the air cleaner's handle bolt and air cleaner cover. Remove the locknut, then remove the platen. Remove the element from the air cleaner base.
2. Carefully check each element for holes or tears. Replace any damaged element.

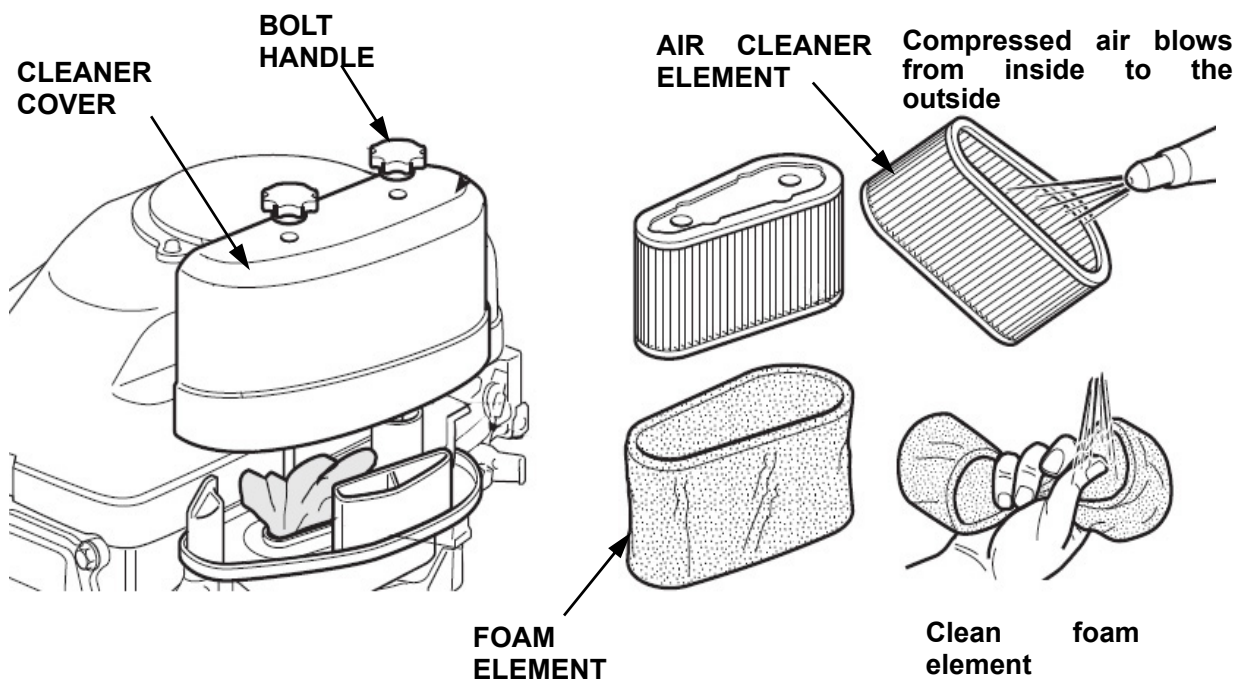

3. Clean the foam element by squeezing it in warm soapy water, rinsing it, and air dry it. You may also use a kind of nonflammable solvent to wash it and then air dry it.
4. Oil the foam element by dipping it in clean engine oil and squeezing out all excess oil.
5. Clean the paper element by tapping it on a hard surface to knock dirt off or by blowing compressed air (at less than 207KPa) through the element from the inside. Never try to brush off the dirt. Brushing will force dirt into the element's fibers
6. Use a wet rag to wipe any dirt off by wiping from the inside of the air cleaner base and cover to their outside. Be careful not to allow any dust grain into the duct leading to the carburetor.
7. Put the paper element in the air cleaner base, making sure that it is positioned evenly and stably.
8. Install the air cleaner cover.

**CAUTION:** *Operating the engine without an air cleaner, or with a damaged air cleaner, will allow dust to enter the engine, causing rapid engine wear. This type of damage is not covered by the Distributor's Warranty.*

# SECTION 3 MAINTENANCE

---

## 3-4 Spark Plug

Recommended types: RC12YC or a spark plug of an equivalent grade.

Replacing the spark plug has the following positive effect:  
Ensuring continuous production of sparks, more reliable starting,

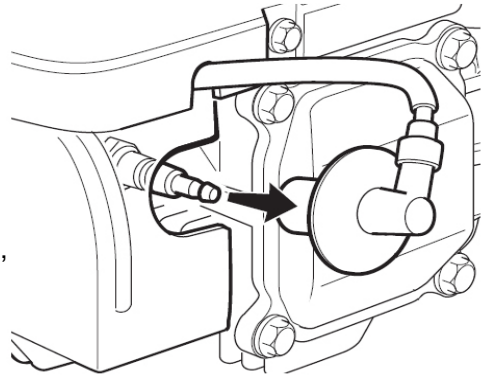

### CAUTION

***Spark plugs of a wrong model or incorrect heat range can cause engine damage.***

1. Remove the spark plug cap, and remove the dirt from around the spark plug.
2. Remove the spark plug with a spark plug wrench.
3. Inspect the spark plug for excessively worn electrodes, chips or cracks in the insulator, or excessive deposits.

Replace the spark plug if you have any doubts about its condition.

4. Measure the electrode gap with a gap gauge; the correct gap is 0.7~0.8mm; if the gap need be adjusted, slightly knock (when the gap is to big), or slightly pry the electrode with a slot type screwdriver (when the gap is too small).
5. Use a spark plug wrench to tighten the spark plug enough to let it press on the washer. If reinstalling a used spark plug, tighten 1/8 to 1/4 of a turn after the spark plug presses on the washer. If installing a new spark plug, tighten 1/2 turn after the spark plug presses on the washer.

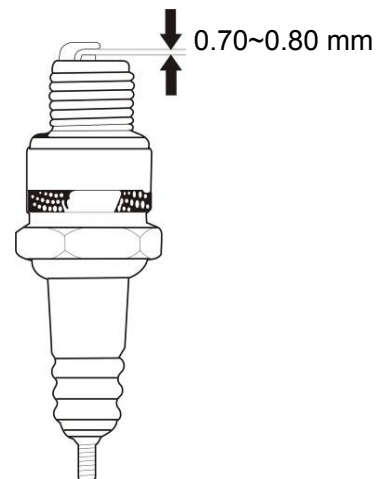

### CAUTION

***A loosely installed spark plug can become hot enough to damage the engine. Over tightening a spark plug can damage the threads in the engine.***

6. Install the spark plug cap on the spark plug.

## 3-5 Valve Clearance

Valve clearance inspection and adjustment must be done with the engine cold.

1. Remove the cylinder head cover, and set the piston at top dead center of the compression stroke (both valves will be fully closed).

# SECTION 3 MAINTENANCE

2. Measure the clearance between the rockerarm and the valve stem with a feeler gauge.

Intake:  $0.15 \pm 0.02$  mm  
Exhaust:  $0.20 \pm 0.02$  mm

3. To adjust valve clearance, hold the rocker arm pivot and loosen the pivot lock nut.
4. Turn the rocker arm pivot to obtain the specified clearance.
5. Hold the rocker arm pivot and tighten the pivot lock nut.
6. Recheck the clearance and readjust if necessary.
7. Install the cylinder head cover.

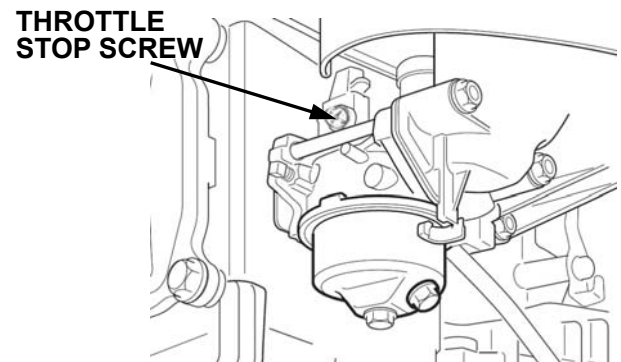
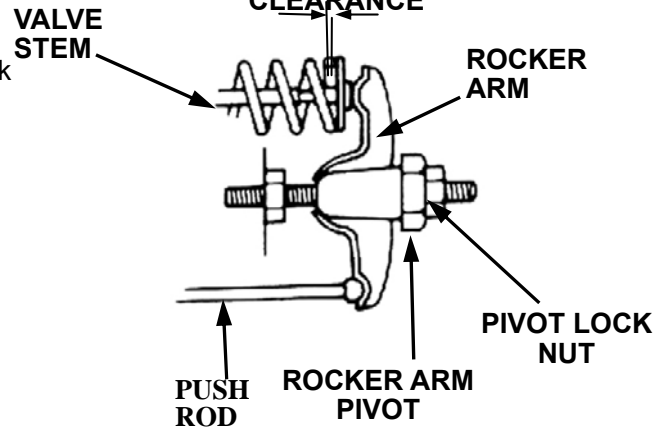
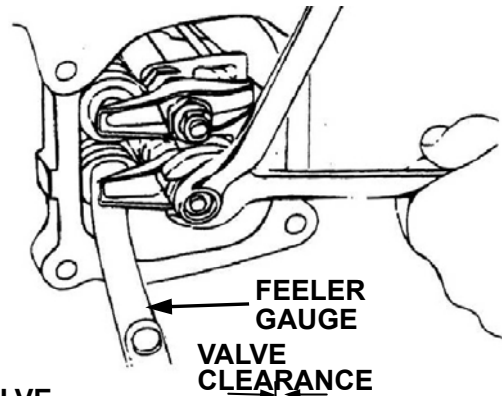

## 3-6 Carburetor

### Idle speed

1. Start the engine. And allow the engine to warm to normal operating temperature.
- With the engine idling, adjust the throttle stop screw to obtain the recommended engine idle speed.

**Recommended idle speed:  $1850 \pm 150$  rpm**

## 3-7 Governor

1. Loosen the governor arm pinch bolt nut but do not remove it.
2. Move the governor arm rearward to fully open the throttle and hold it in this position.
3. Rotate the governor arm shaft clockwise until limit is reached, hold it there with a pair of pliers.

Tighten the governor arm pinch bolt nut to  $11N \cdot m$  to secure the governor arm to the governor arm shaft.

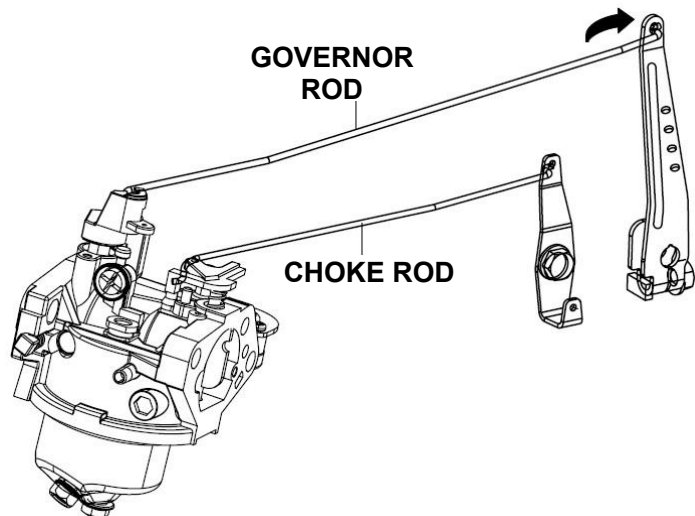

4. Check to be sure the governor arm and throttle valve move freely.

# SECTION 3 MAINTENANCE

---

## 3-8 Oil Filter Replacement

If your engine has an oil filter, replace it at least once a season.

1. Use an oil filter spanner or a pipe spanner to rotate the oil filter counter clockwise, and to replace it.
2. Check sealed surfaces of oil filter's adapting flange for debris or packing, clean them if necessary.
3. Drip a little clean engine oil on filter's washer. Install the new filter, tighten it until the washer firmly presses on the adapting flange, then make another 1/2~3/4 turn to fix the filter.

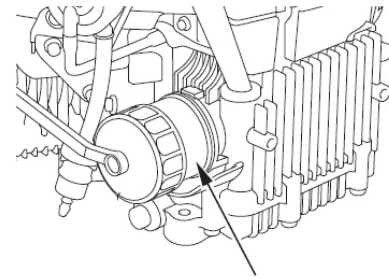

**OIL FILTER**

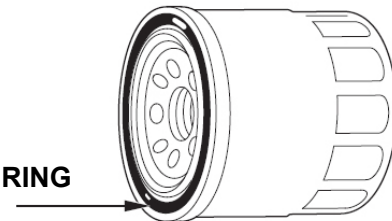

**SEAL RING**

## 3-9 Muffler

Long use of the muffler can cause carbon deposit, which will severely affect the exhaust system; in order to let exhaust system work more reliably, we normally need to remove the carbon deposit from the muffler.

Use a hand hammer to gently knock the muffler, and blow it with compressed air to remove the carbon deposit inside it.

If the muffler has water drops in it, and severe erosion, which cause higher exhaust noise, replace it with a new one.

Never use wires to clean, or the acoustic absorbent will be scraped off, and acoustic absorbing performance will be worse.

Never reuse the muffler gasket.

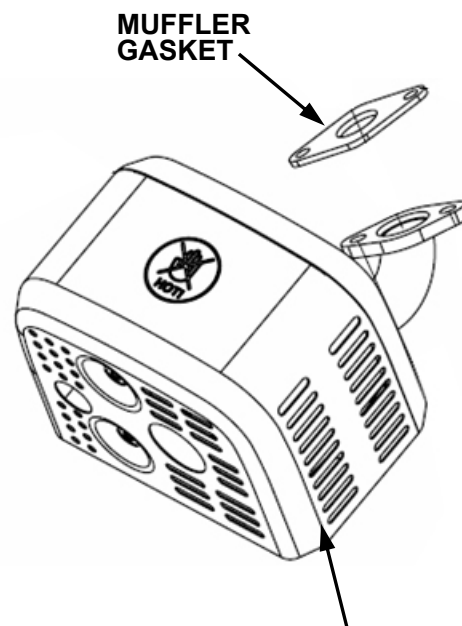

**MUFFLER GASKET**

**MUFFLER**

# SECTION 4 Troubleshooting

## 4-1 Hard Starting

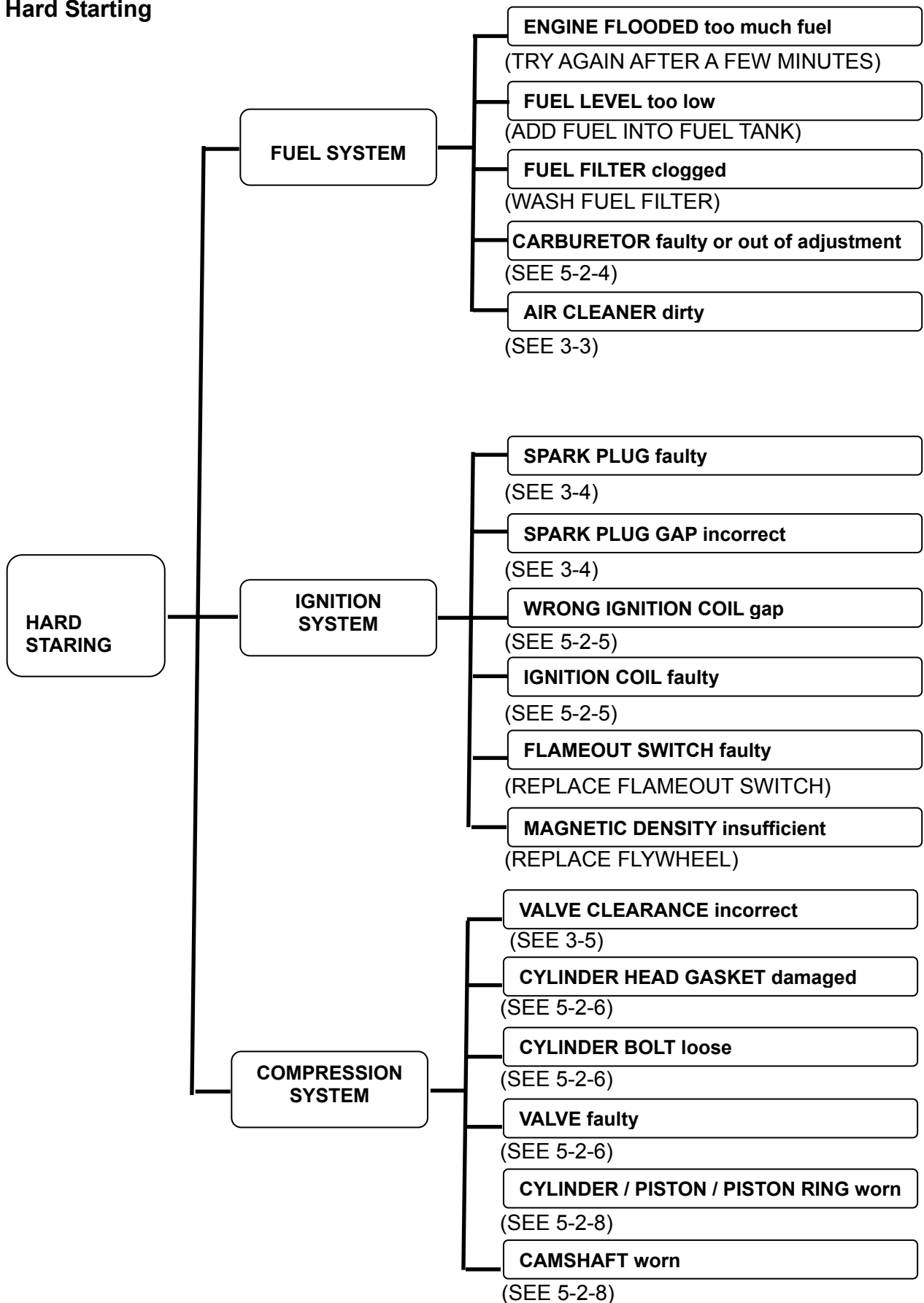

# SECTION 4 Troubleshooting

## 4-2 Low Power

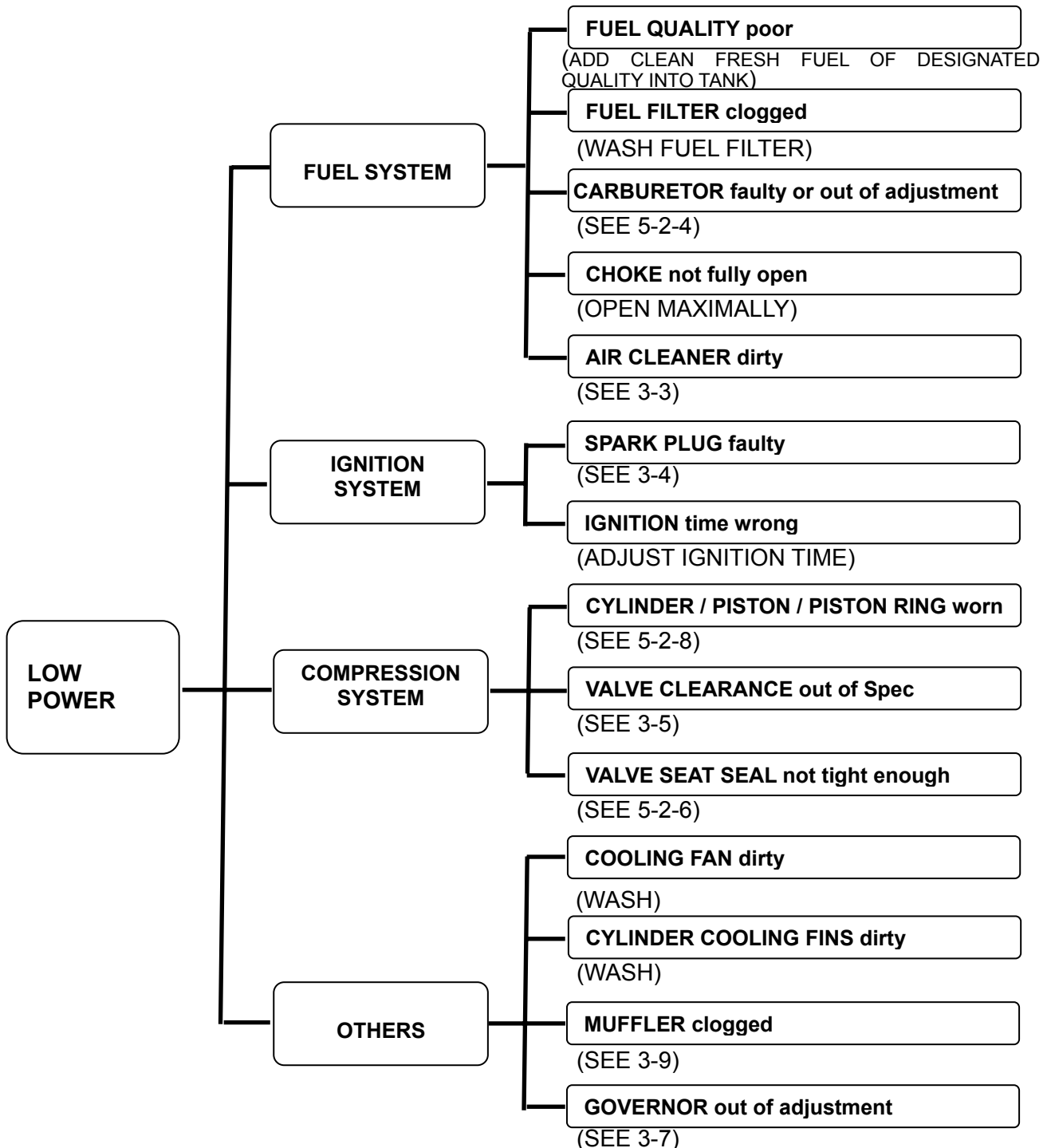

# SECTION 4 Troubleshooting

## 4-3 Speed Unstable

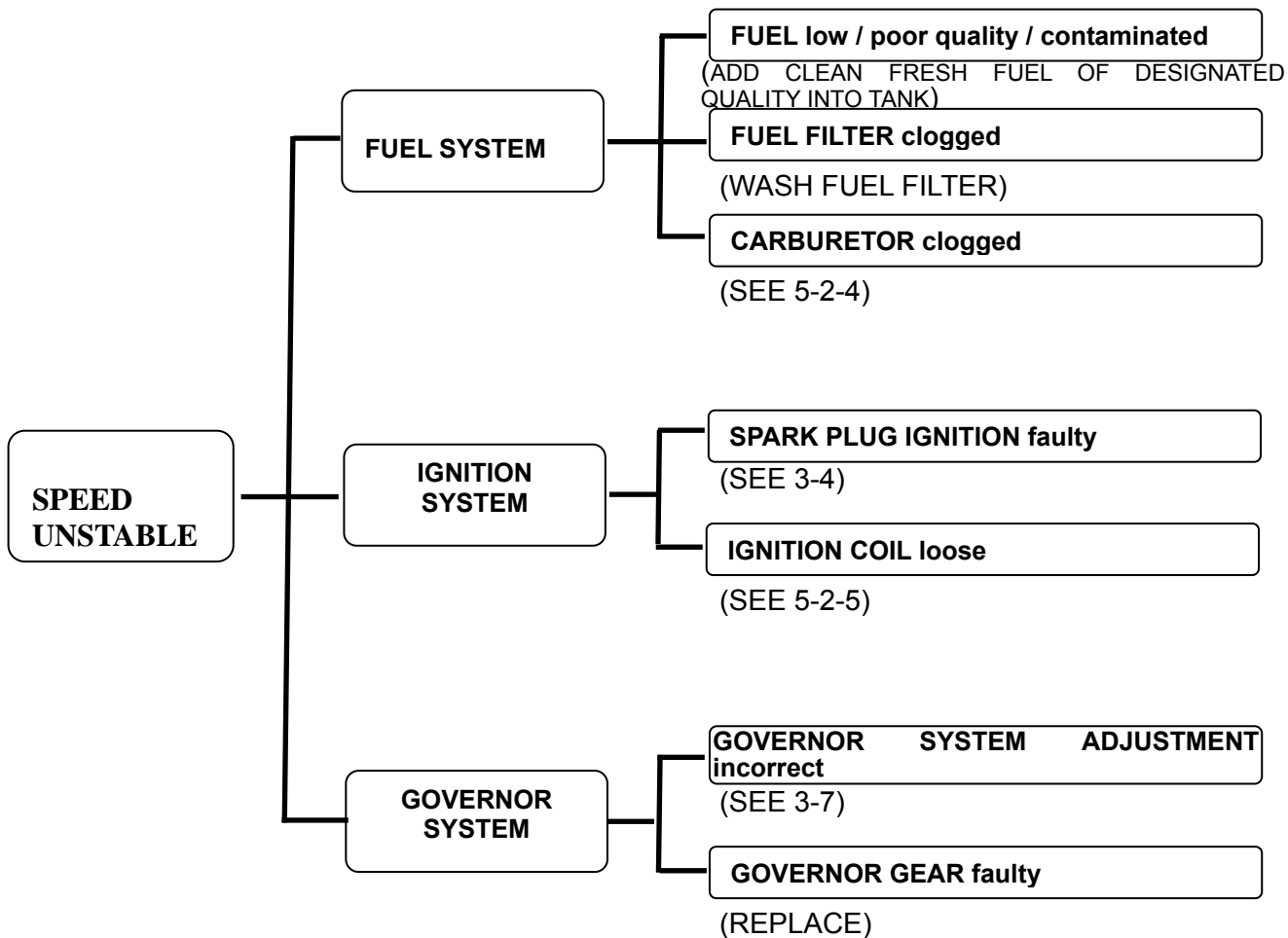

# SECTION 4 Troubleshooting

## 4-4 Exhaust Color Abnormal

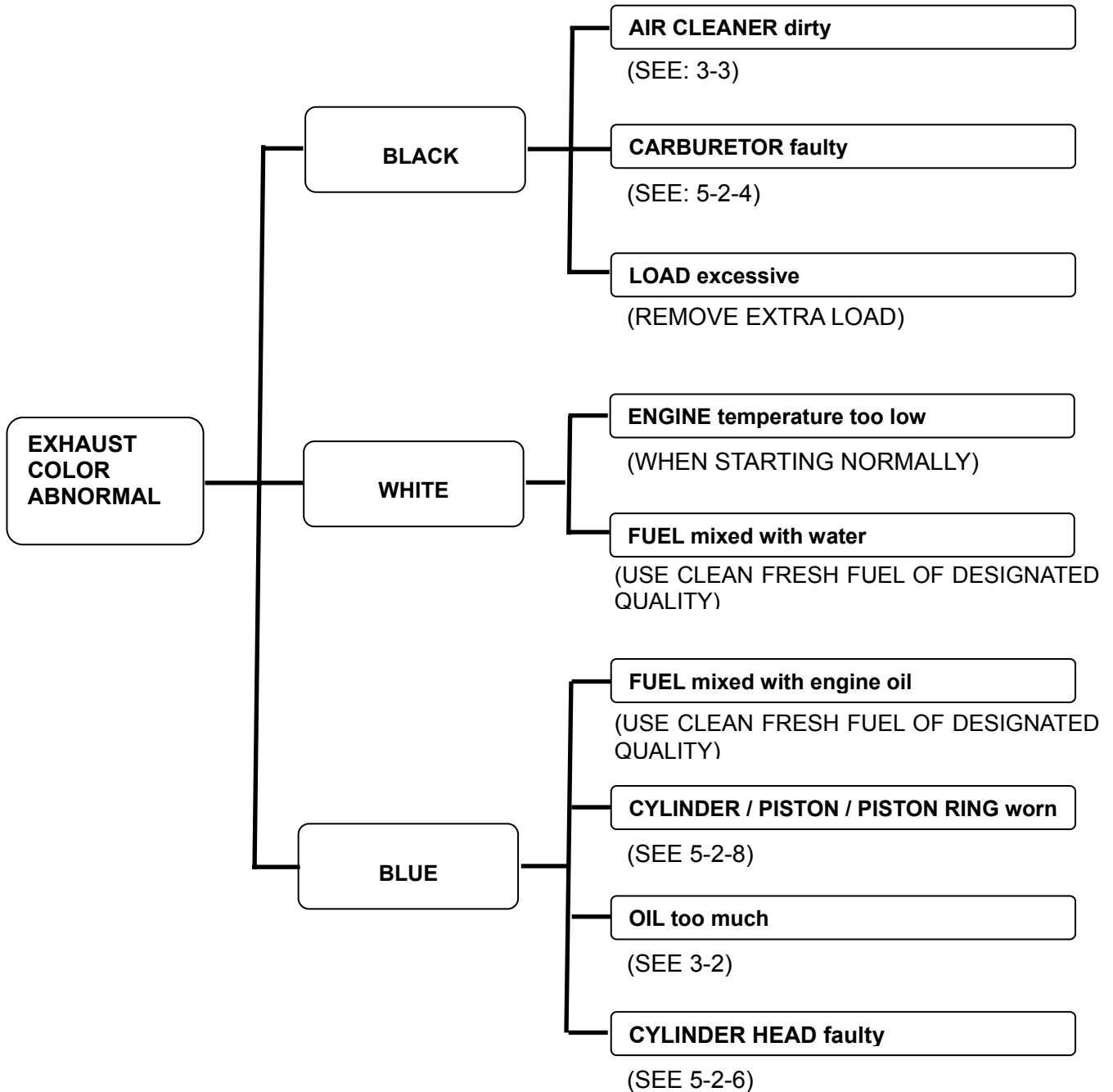

# SECTION 4 Troubleshooting

---

## 4-5 Engine Liable to Stall

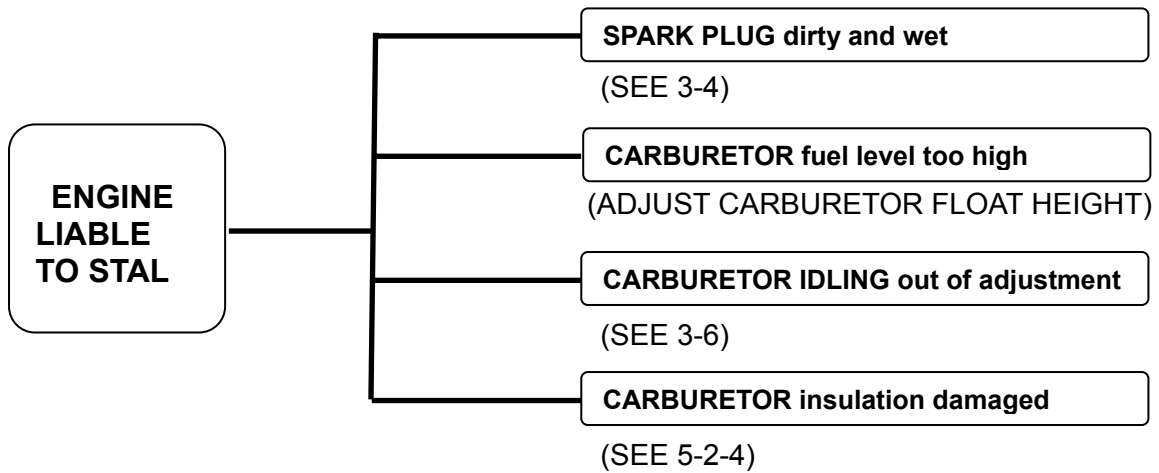

## 4-6 Engine Speed Does Not Increase

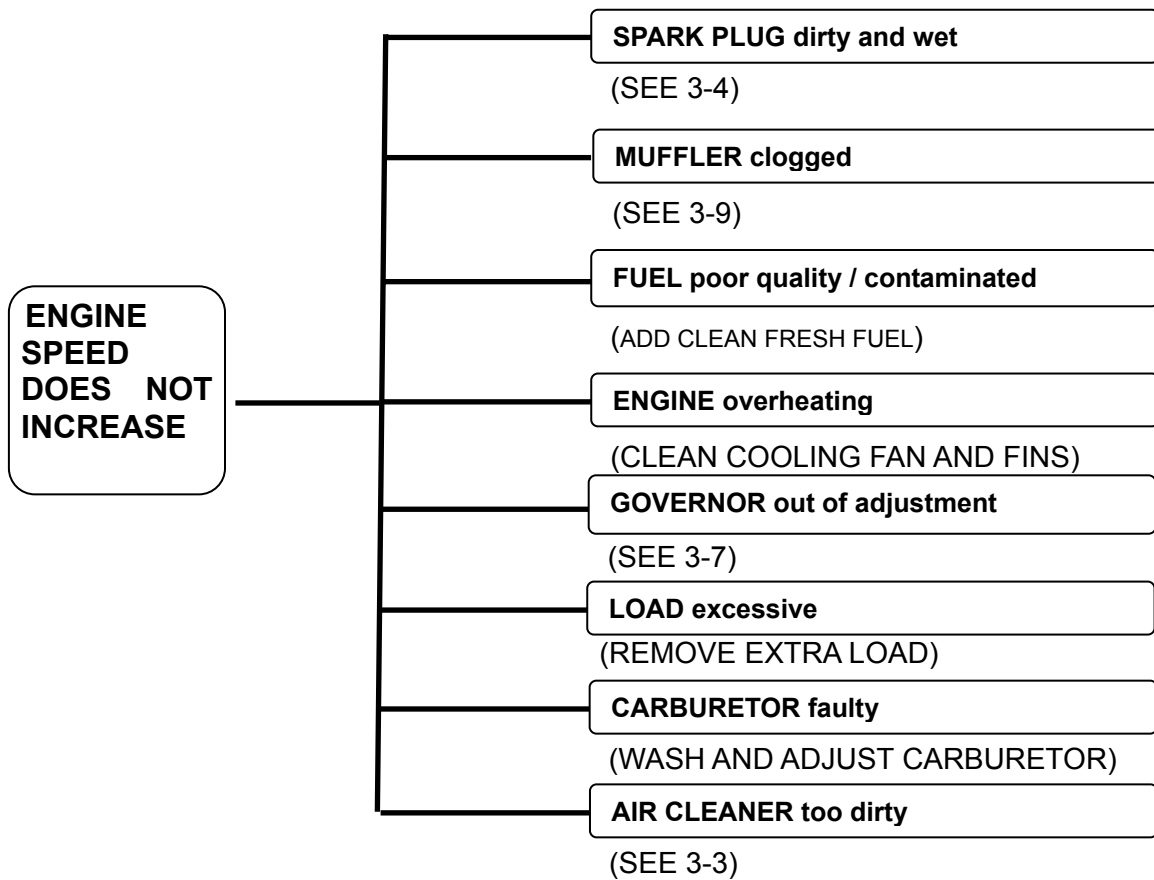

# SECTION 4 Troubleshooting

---

## 4-7 Engine Overheating

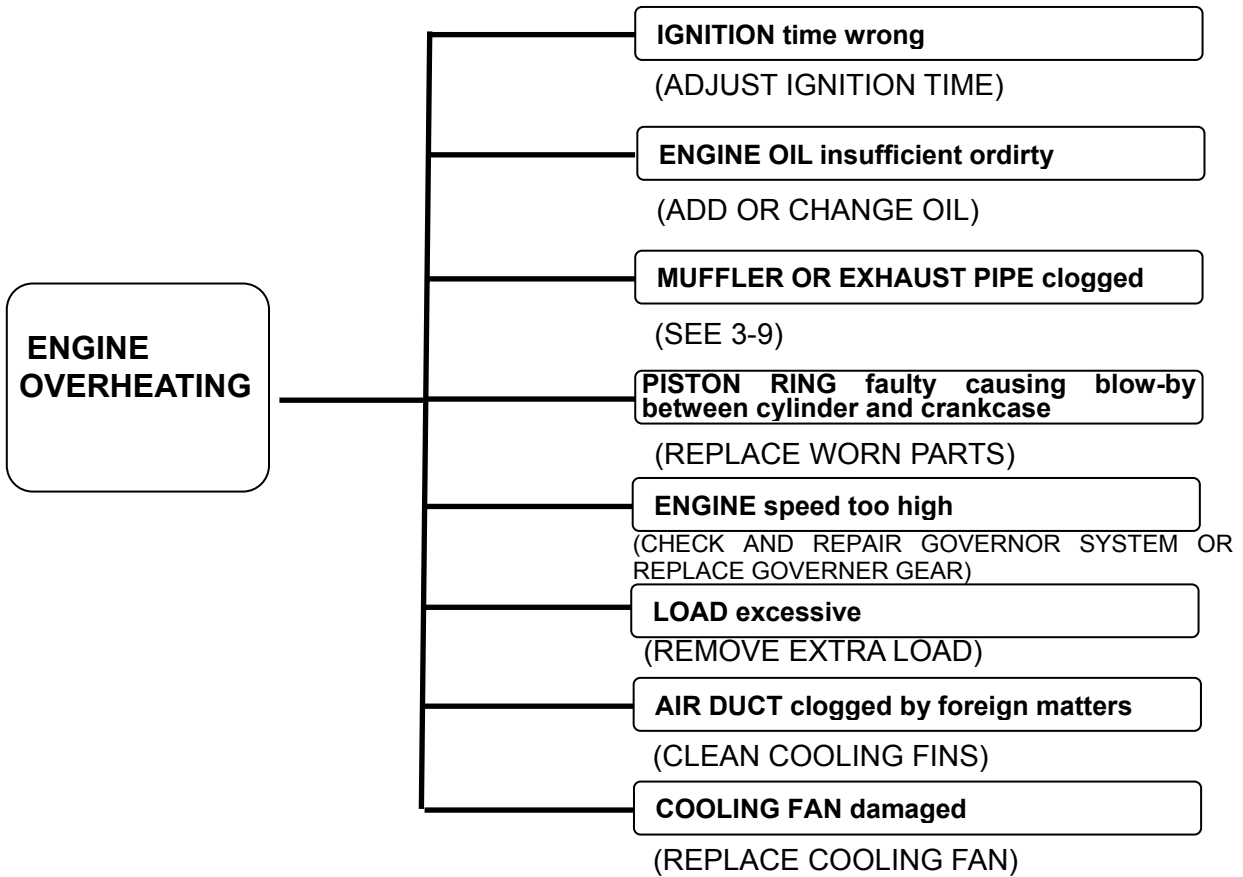

# SECTION 4 Troubleshooting

## 4-8 Engine's Abnormal Sound

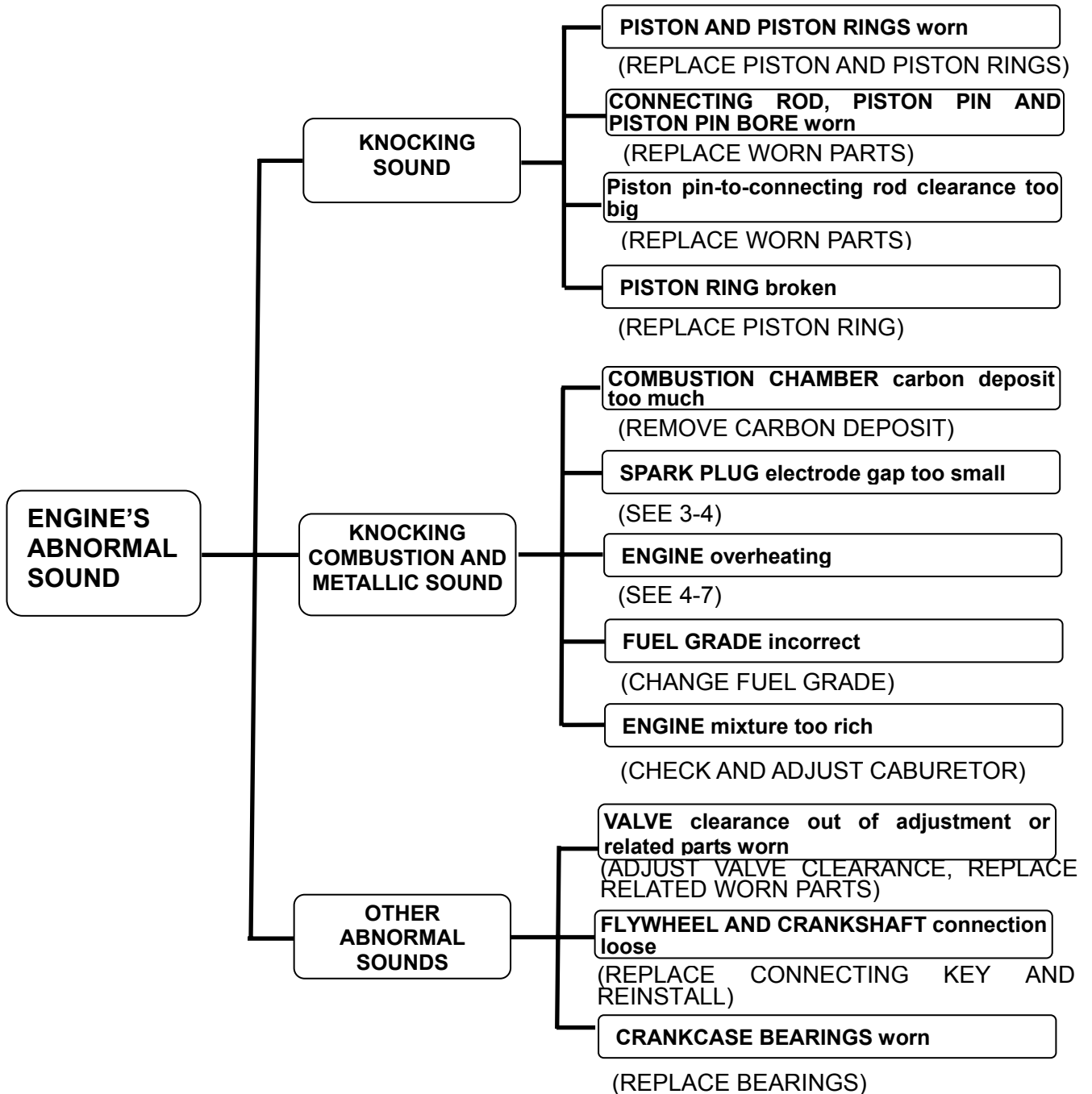

# SECTION 4 Troubleshooting

## 4-9 Electric Starting System Failure

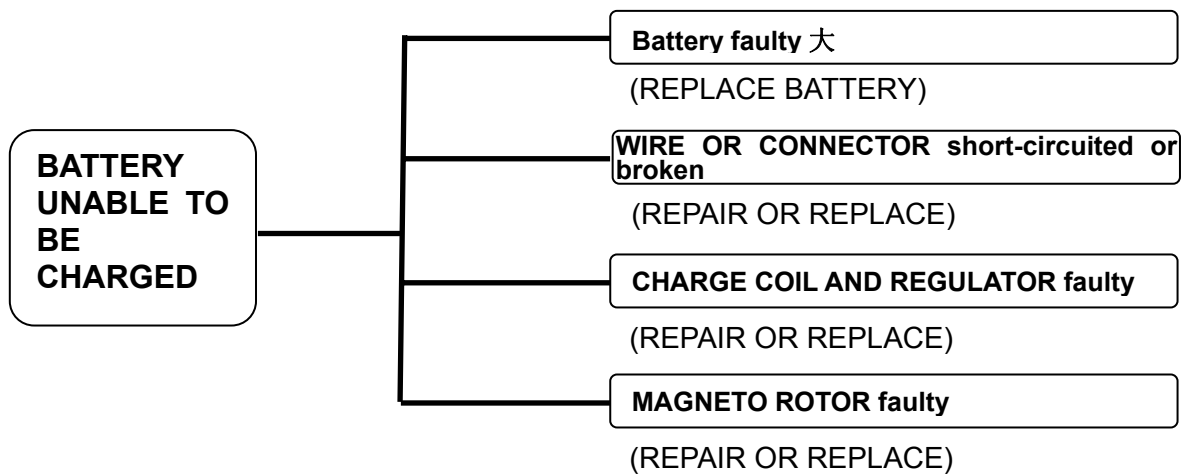
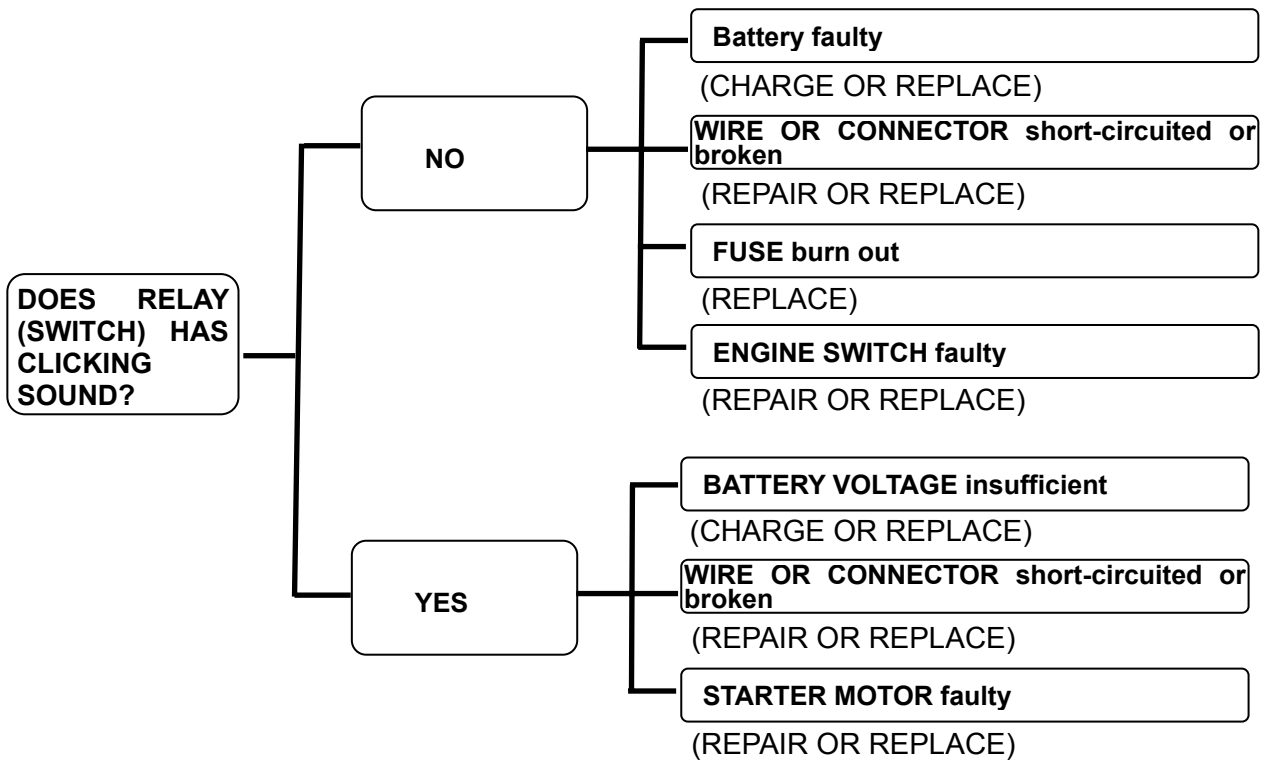

# SECTION 4 Troubleshooting

---

## 4-10 Cylinder Compression Check

- 1) Remove spark plug cap and spark plug.
- 2) Install a compression gauge in the spark plug hole.
- 3) Use a particular dynamometer to start the engine, then measure cylinder compression.

Cylinder compression	Speed 1400rpm, 8.0~10.0 Kg/cm <sup>2</sup>
----------------------	---

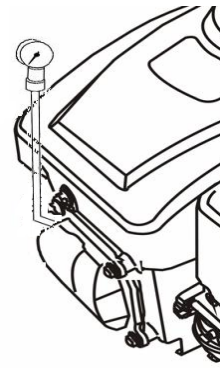

### CAUTION

*When speed it over 1000 rpm and valves are closed, we can measure the correct cylinder compression.*

## 4-11 Spark Plug Check

- 1) Remove the spark plug.
- 2) Install the spark plug into the spark plug cap.
- 3) Ground the spark plug's (-) electrode (threaded section), pull starter to check if there is spark at the electrode joint.

### WARNING

Never touch spark plug's terminals by wet hand when testing.

If touching the high tension cord by wet hand, starting can produce a high electric voltage, which is very dangerous.

Sprinkled fuel can cause fire around the spark plug. First, clean the fuel, then check. When checking, keep far away from the spark plug hole.

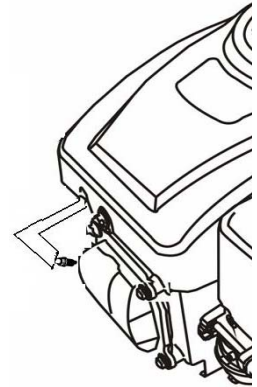

# SECTION 5 Disassembly and Service

---

## 5-1 Precautions for Disassembly

### 5-1-1 Disassembly

1. Be familiar with the machine's structure and working principles before disassembly, it is the prerequisite of correct disassembly.
2. Try best not to detach the parts that can avoid being detached. Aimless detaching not only increases work load of the repair, but also deteriorates the originally good fitting relation between parts and fitting accuracy, which leaves new hazards of failure.
3. Use suitable removing tools and correct removing methods. Never knock with a big force during removing to avoid parts' deformation and damage. In order to improve repairing efficiency, the special removing tools should be preferred tools.
4. Disassembly work should be carried out step by step from the outside to the inside. Generally disassembly is carried in the order of "Whole machine Assemblies Subassemblies Parts".
5. In order to ensure smooth assembly after repairing, the following requirements should be met during disassembly:
  - 1) Check the marks, and make marks, (such as lines, arrows, and texts marked on some parts). If any part has no mark, make a mark on its non-working surface to help reinstall it correctly.
  - 2) Reasonably put parts based on their categorization. Parts of the same assembly or subassembly should be placed together. Parts liable to deformation or missing, such as the washers, should be place separately.

### 5-1-2 Reassembly

1. The place for assembly should be clean.
2. Prepare suitable assembling tools and devices.
3. Parts must be cleaned thoroughly; dust, dirt, earth, metal filings, carbon deposit, oil sludge and other impurities must be removed from its surface, holes, grooves, oil passage, etc. Compressed, detergent, etc. can be used for cleaning.
4. Carry out assembly in the order contrary to that for disassembly, i.e. in the order of "from inside to outside, from major parts to auxiliary parts" and "parts subassemblies assemblies whole machine".
5. Take care to check the part mark and assembling mark of each part when assembling to avoid missing or wrong installation.
6. When installing fasteners, tighten them in the order of "from the center to sides" and by turning several times in a crisscross pattern. Then use a torque wrench to fasten them to the specified torque values.
7. When assembling, all gaskets should be replaced in a timely manner.
8. Carry out trial run of the machine after the whole machine has been assembled and adjusted, and no fault is found upon check.

# SECTION 5 Disassembly and Service

## 5-2 Disassembly and Service of Engine

### 5-2-1 Air Cleaner

#### Disassembly

- 1) Remove the 2 M6 nuts and M6×35 bolts used to fix the air cleaner, detach the breather tube, remove the air cleaner
- 2) Pull the breather tube's other end out of the crankcase to remove the breather tube.

#### Precautions for reassembly:

- 1) Confirm no installation of any of the air cleaner's gaskets is missing, and assembly is correct.
- 2) Check whether air cleaner's foam element and paper element are damaged or dirty, carry out timely cleaning or replacement if necessary.

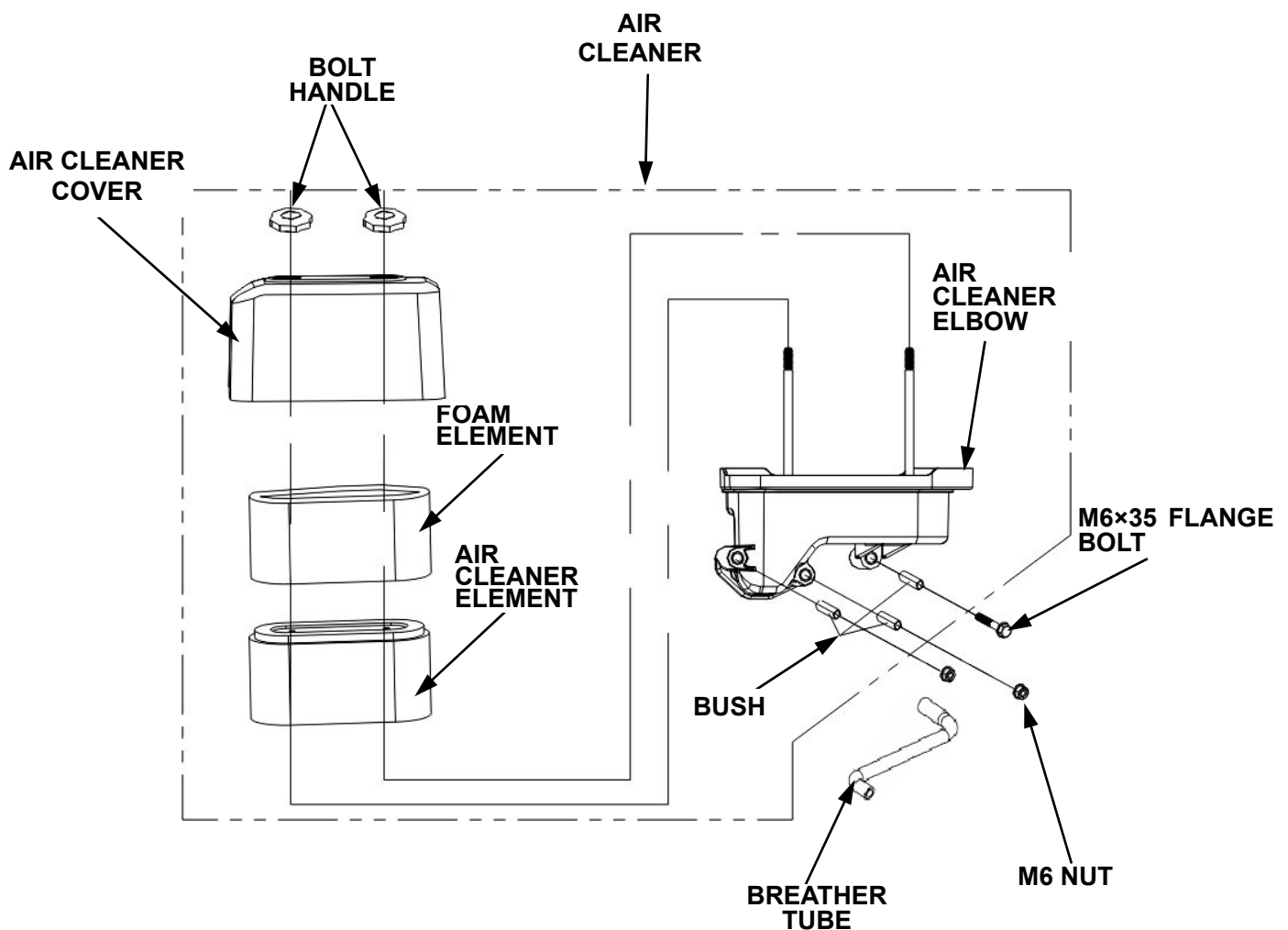

# SECTION 5 Disassembly and Service

## 5-2-2 Cooling Fan, Fan Cover Disassembly

- 1) Remove the 4 hexagon shoulder bolts, and detach fan cover comp. and cooling fan cover.
- 2) Remove the M16 nuts, and detach starter pulley and cooling fan.

### Precautions for reassembly:

- 1) Three pins on the back side of the cooling fan must be aligned with the three holes on the flywheel that are near the cylindrical surface, the starter pulley is positioned on the cooling fan.
- 2) Wash the dirt and dust off the cooling fan; if cooling fan is damaged, replace it.

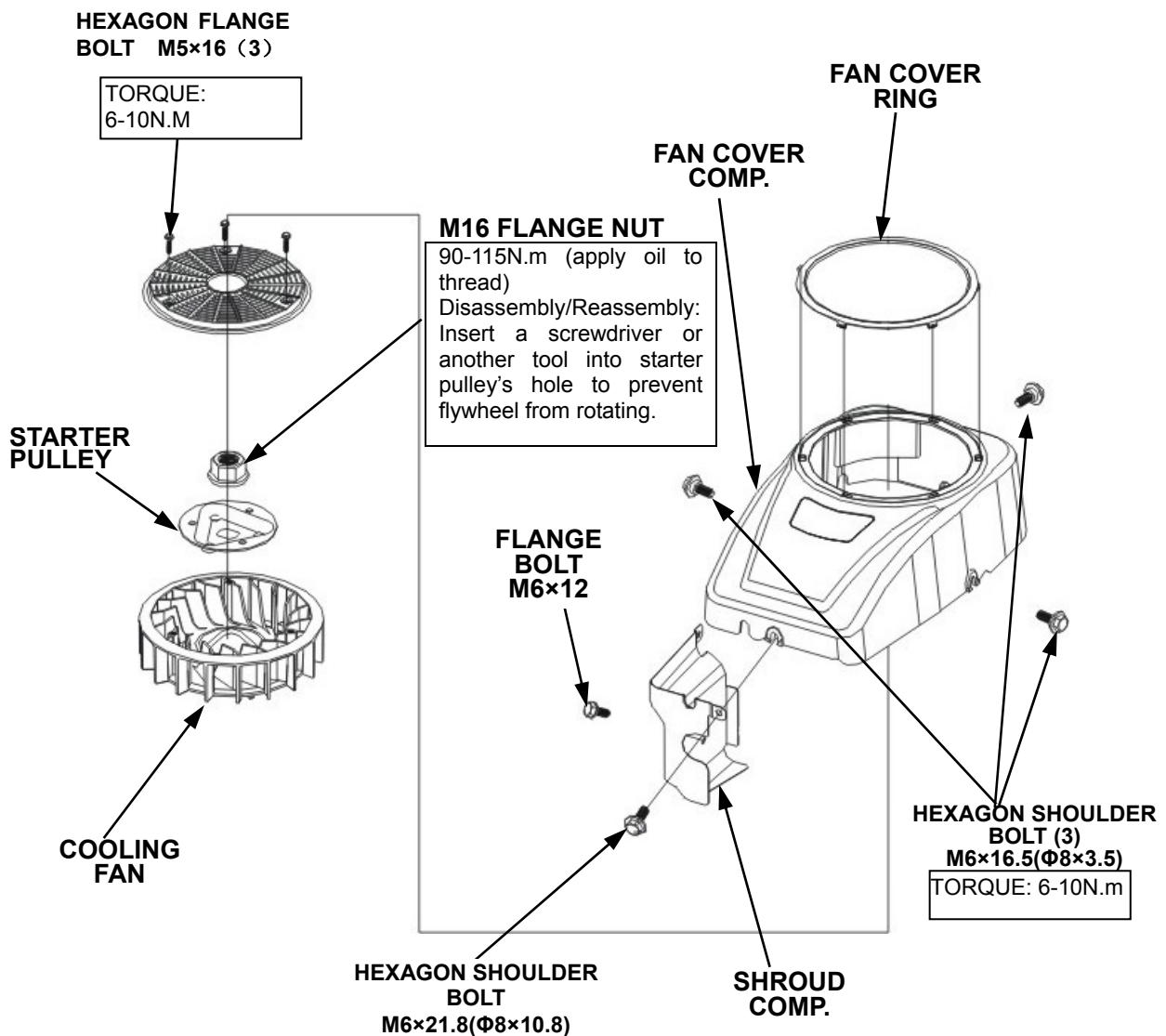

# SECTION 5 Disassembly and Service

## 5-2-3 Governor System

### DISASSEMBLY

- 1) Use a pair of long nosed pliers to remove the governor spring, then remove nuts and governor arm bolt, and remove governor arm and governor rod.
- 2) Remove the hexagon shoulder bolts and choke stay, detach the choke rod from the carburetor's choke lever hole and choke stay hole, detach choke rod from choke stay hole and control assembly.
- 3) Remove two M6×14 bolts, detach the control assembly.

### PRECAUTIONS FOR REASSEMBLY:

- 1) Confirm choke rod, choke stay and throttle rod are installed in proper place, and choke stay can rotate freely.
- 2) Loosen governor arm's fastening nut, turn governor arm backward to the position where throttle is fully open, hold it in this position. Turn the governor arm shaft clockwise until it reaches the extreme limit, use a pair of pliers to hold it, tighten governor arm fastening nut. Check whether governor arm and throttle act properly and easily.

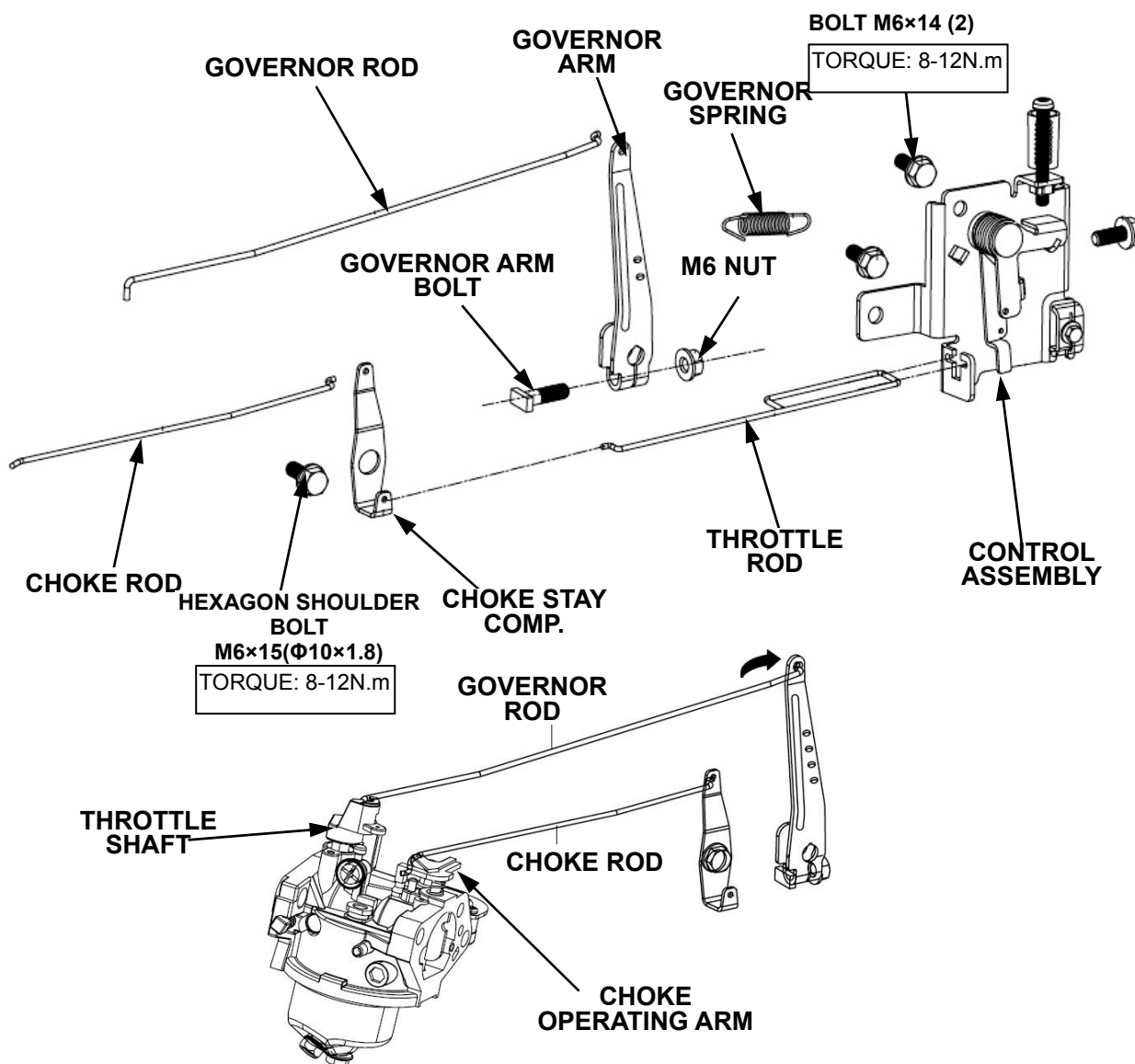

# SECTION 5 Disassembly and Service

## 5-2-4 Carburetor

### DISASSEMBLY

- 1) Remove air cleaner packing, fuel tube, governor rod, and choke rod, remove the carburetor.
- 2) Remove M6×12 hexagon flange bolts, detach the cylinder head shroud, carburetor packing, carburetor insulator, and intake pipe packing.
- 3) Remove gasoline pump bracket, detach the gasoline pump.

### PRECAUTIONS FOR REASSEMBLY:

- 1) Oil drain plug must be loosened before installing the carburetor to drain off fuel; smoking and flame are prohibited.
- 2) Use compressed air to remove dirt and dust from the passage before installing carburetor insulator, pay attention to the directions the inside and outside are in when installing.
- 3) If the fuel tube has aged and cracked, or carburetor packing is damaged or deformed, replace them.

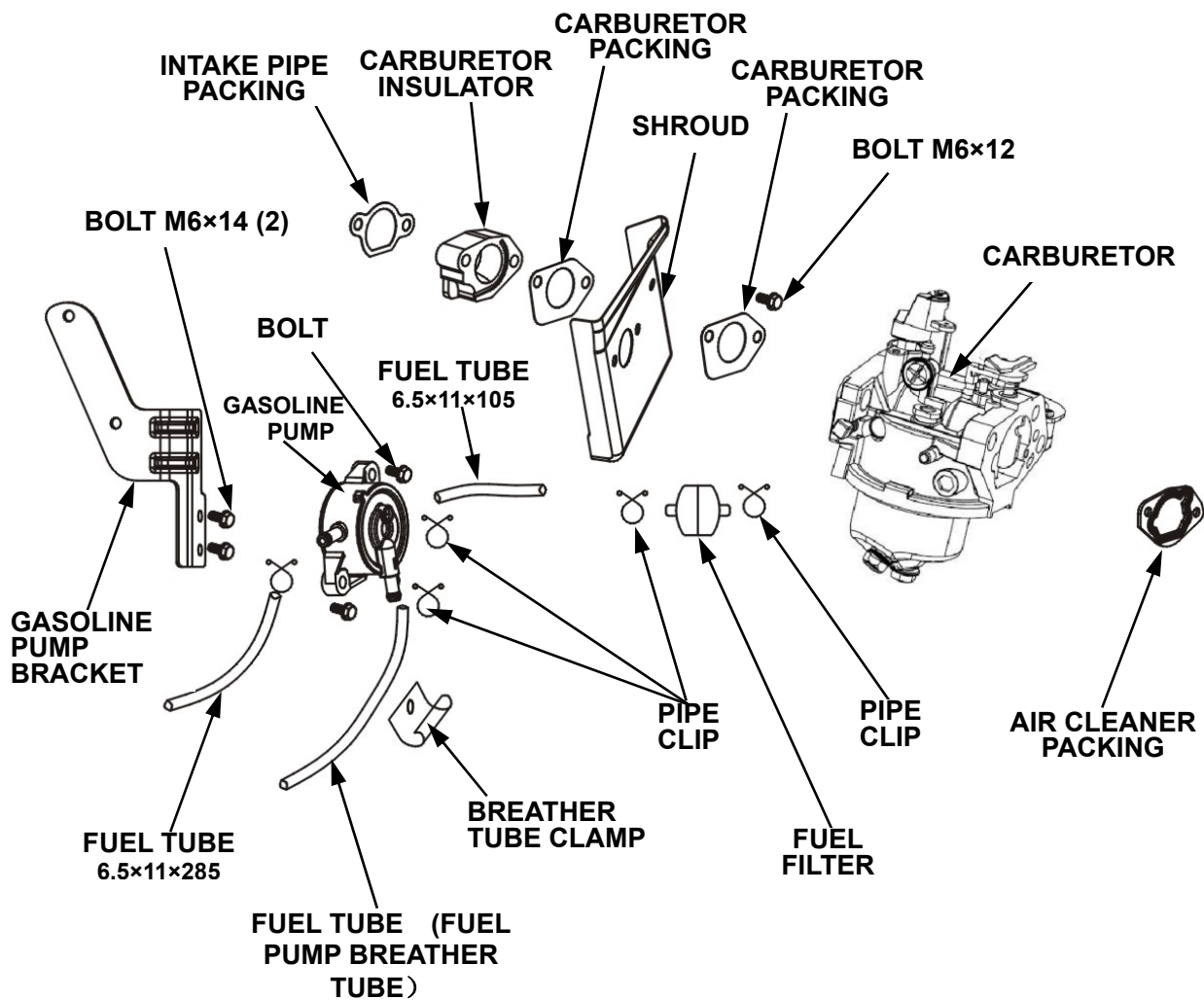

# SECTION 5 Disassembly and Service

Oil drain plug must be loosened before removing and repairing carburetor to drain off fuel, smoking and flame are prohibited.

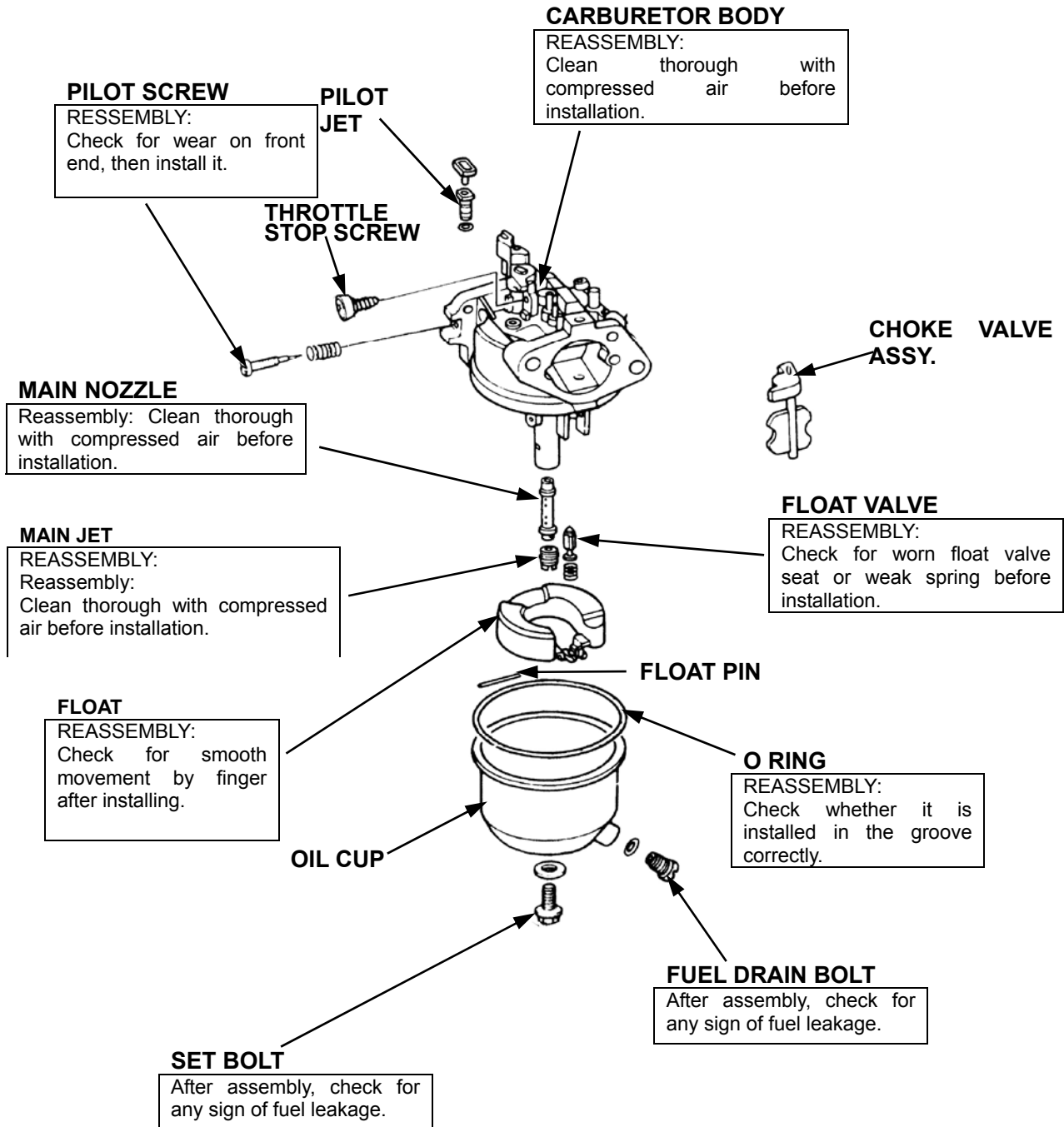

# SECTION 5 Disassembly and Service

## 5-2-5 Flywheel, Ignition Coil, Starter Motor

### DISASSEMBLY

- 1) Remove two M6×25 bolts, swallow-tailed clamp, flameout wire, and remove ignition coil.
- 2) Don't knock the flywheel with a hammer, use a available flywheel puller to remove the flywheel; the flywheel puller should avoids the magnet section of the flywheel.
- 3) Remove the M6×12 bolts, and the regulator/rectifier; remove motor fastening bolts, the starter motor and regulator/rectifier bracket.

### PRECAUTIONS FOR REASSEMBLY:

- 1) Apply an appropriate amount of grease to crankshaft's flywheel end when installing the flywheel; ensure there are no metal objects stuck to the magnet; after installing the flywheel, check whether the woodruff key is correctly in the key slot.
- 2) When installing the ignition coil, check whether high tension cord's insulation is damaged or cracked to avoid electric leakage; adjust the gap between the ignition coil and the flywheel.

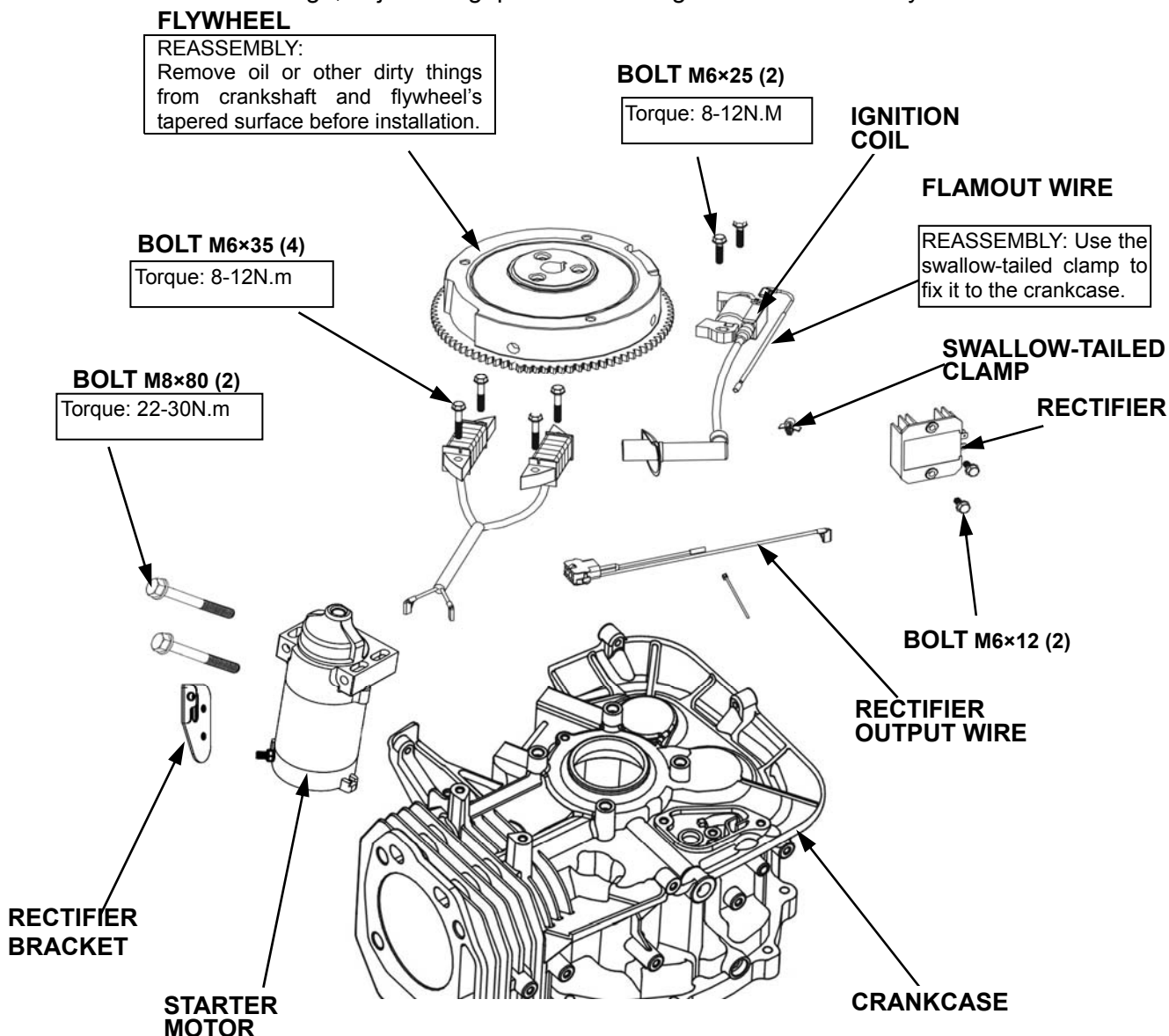

# SECTION 5 Disassembly and Service

## Ignition coil gap adjustment

When reinstalling the ignition coil, adjust the ignition coil gap.

- 1) Lightly tighten ignition coil mounting bolt.
- 2) Insert the feeler gauge or a piece of paper of the same thickness between the flywheel and ignition coil as shown.
- 3) Push the ignition coil against the flywheel by hand and tighten the two bolts.

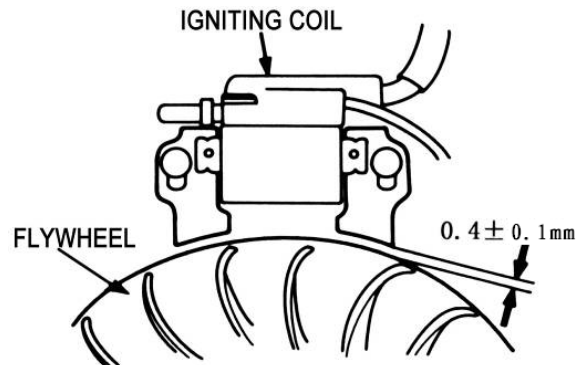

Ignition coil gap	0.4±0.1 mm
-------------------	------------

### NOTE

- a) **Adjust both ends of the ignition coil to the same gap.**
- b) **Avoid the magnet section of the flywheel when adjusting.**
- c) **Inspection.**

## Ignition coil:

<Primary side>

Measure the resistance of the primary coil by attaching one ohmmeter lead to the ignition coil's primary lead while touching the other test lead to the iron core.

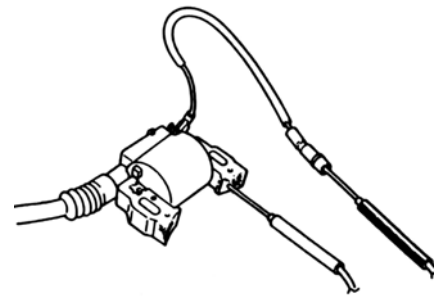

Primary side resistance value	1.0-1.4 Ω
-------------------------------	-----------

<Secondary side>

Measuring the resistance of the secondary side of the coil by removing the spark plug cap and touching one test lead to the spark plug lead wire while touching the other lead to the coil's iron core.

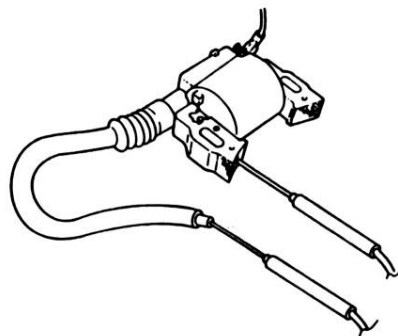

Secondary side resistance value	5.2-6.4 KΩ
---------------------------------	------------

## CAUTION

# SECTION 5 Disassembly and Service

*A false reading will result if the spark plug cap is not removed.*

## 5-2-6 Cylinder Head, Valves

### DISASSEMBLY

- 1) Remove cylinder head bolt, and remove cylinder head cover and cylinder head cover gasket.
- 2) Remove rocker arm component, plate assembly, push rod, and spark plug.
- 3) Remove four M10×85 cylinder head bolts, remove cylinder head, cylinder head gasket, then remove valves.

### PRECAUTIONS FOR REASSEMBLY:

- 1) Loosen and tighten cylinder head bolts and cylinder head cover bolts in a crisscross pattern in 2-3 steps.
- 2) Before installing cylinder head, remove any carbon deposits from the combustion chamber and inspect the valve seats. Measure the cylinder compression after reassembly.
- 3) Check and adjust valve clearance until it is in the specified range after installing cylinder head.

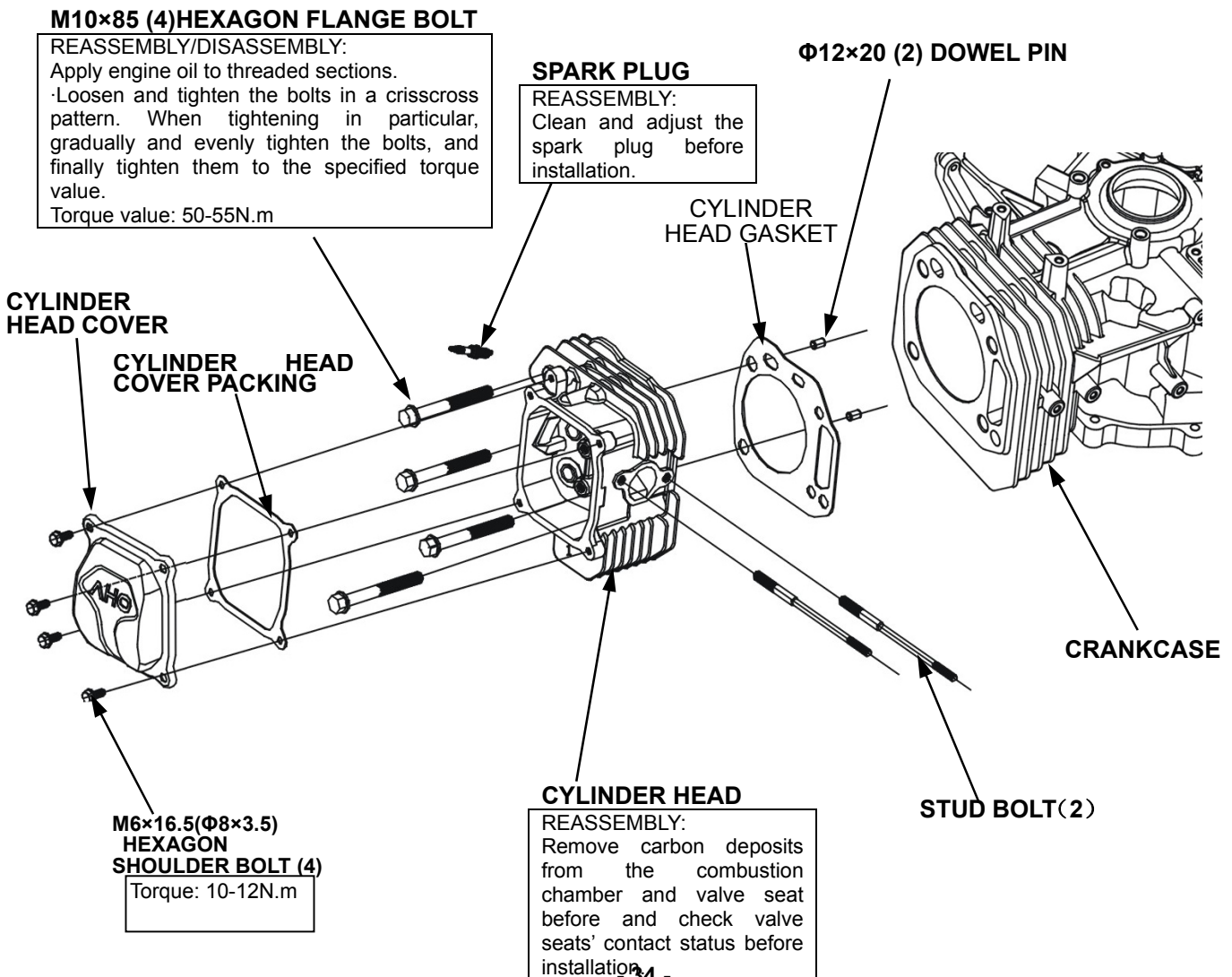

# SECTION 5 Disassembly and Service

## DISASSEMBLY/REASSEMBLY

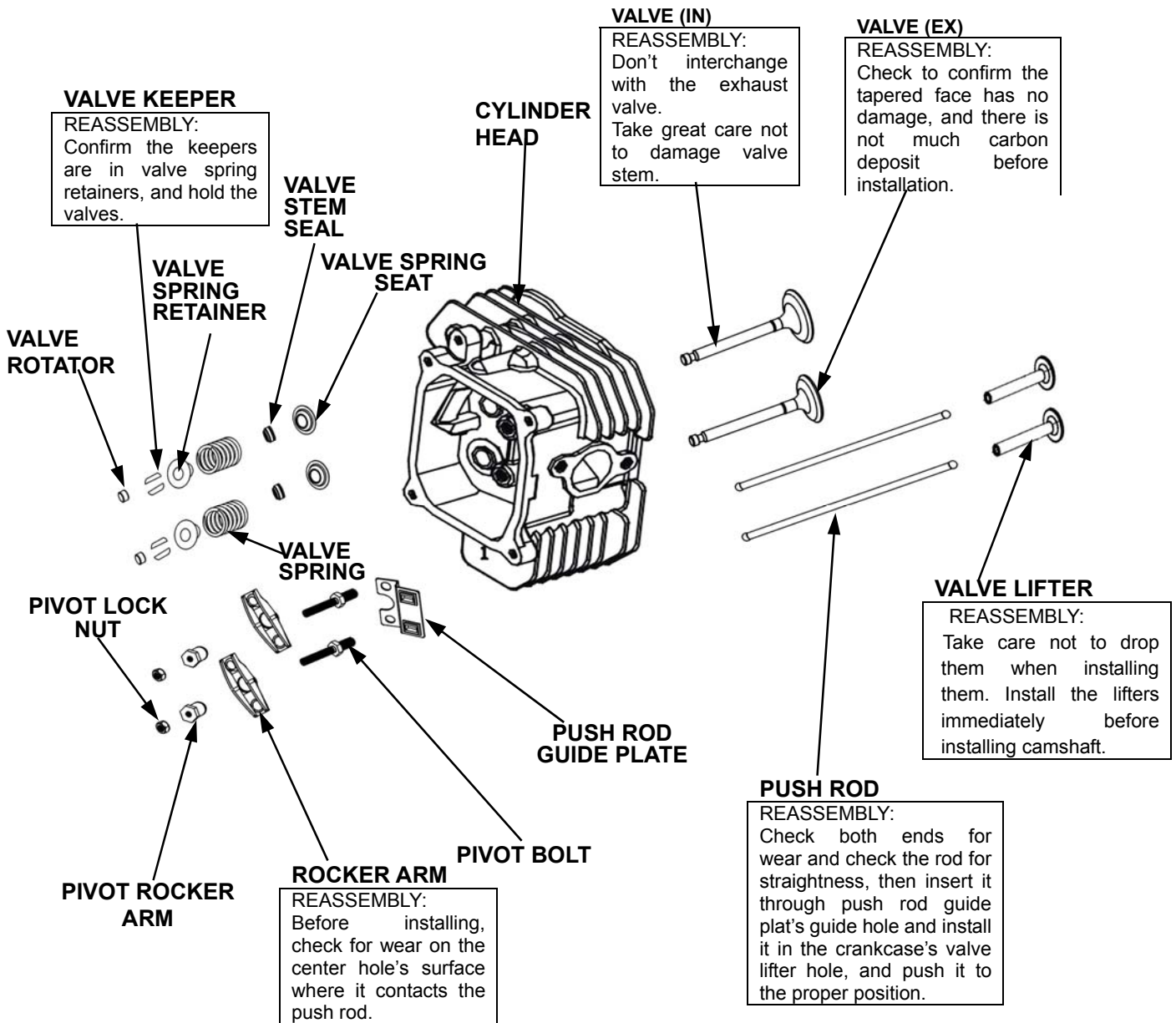

# SECTION 5 Disassembly and Service

## Valve spring free length

Measure free length of valve spring.

Standard	Service limit
39.5mm~40.5 mm	39mm

Replace the spring if it is shorter than the standard value or beyond service limit.

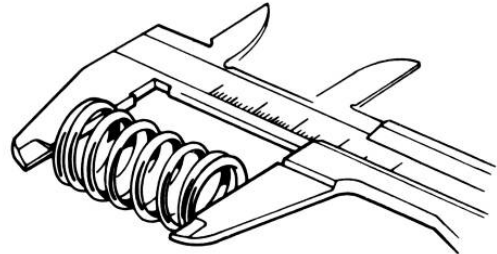

## Valve seat width

Remove carbon deposits from the combustion chamber, check the valve seat for pitting or other damage. Measure the valve seat width.

Standard	Service limit
0.8mm~1mm	1.5 mm

If the valve seat width is under the standard, or beyond service limit, recondition the valve seat.

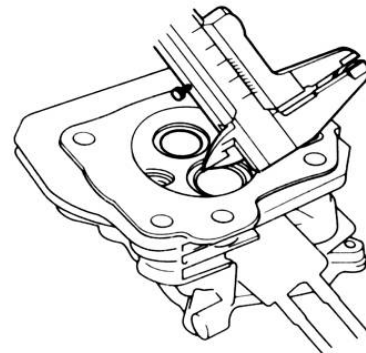

## Cylinder head

1.Remove carbon deposits from the combustion chamber.

Clean off any gasket material from the cylinder head surface.

2. Check the spark plug hole and valve areas for cracks.

3. Check the cylinder head for warpage with a straight edge and a feeler gauge as shown.

Service limit	0.10 mm
---------------	---------

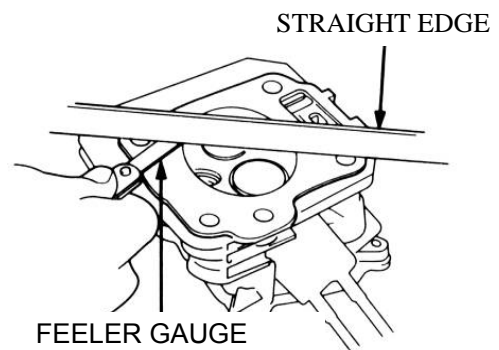

## Valve stem O.D.

Inspect each valve for face irregularities, bending or abnormal stem wear.

Replace the valve if necessary. Measure and record each valve

# SECTION 5 Disassembly and Service

stem O.D.

	Standard	Service limit
IN	6.565~6.580 mm	6.550mm
EX	6.545~6.560mm	6.530mm

Replace the valves if stem O.D. is smaller than the service limit.

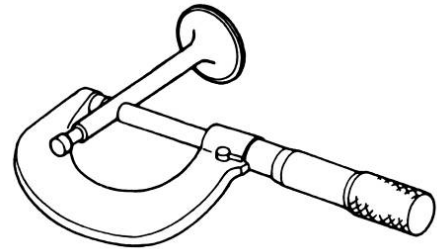

### Valve guide I.D.

Ream the exhaust valve guide to remove any carbon deposits before measuring.

Measure and record each valve guide ID.

Standard	Service limit
6.600~6.615 mm	6.70 mm

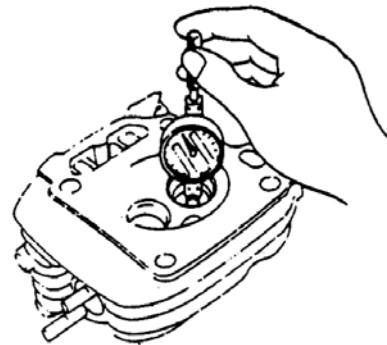

### Guide –to- stem clearance

Subtract each valve stem O.D. from the corresponding guide I.D. to obtain the guide-to-stem clearance.

	Standard	Service limit
IN	0.020~0.050 mm	0.150 mm
EX	0.040~0.070 mm	0.170 mm

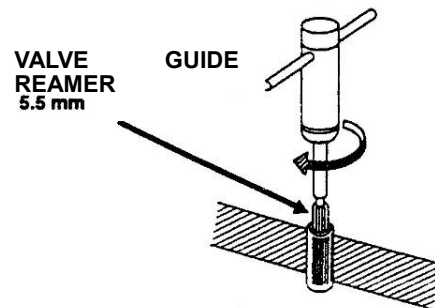

If the guide-to-stem clearance exceeds the service limit, determine if a new guide with standard dimensions can bring the clearance within service limit; if it can, replace the guide (or cylinder head ) as necessary and ream the valve guide to obtain a better fit. If the guide-to-stem clearance exceeds the service limit with new guides, replace the valves too.

Recondition the valve seat whenever the valve guide is replaced.

# SECTION 5 Disassembly and Service

## Cylinder head service

### Exhaust valve guide replacement

The intake valve guide is not replaceable. If the intake valve guide is beyond the service limit due to wear, replace the cylinder head.

### Replace the cylinder head

1. Chill the replacement exhaust valve guide in the freezer section of a refrigerator for about an hour.
2. Use a hot plate or oven to heat the cylinder head evenly to 150°C

Check the temperature with a temperature indicating stick (available at welding supply stores) or an equivalent tool.

Wear heavy gloves to prevent burns when handling heated cylinder head.

### CAUTION

**Do not use a torch to heat the cylinder head; warpage of the cylinder head may result.**

**Do not get the head hotter than 150 °C; excessive heat may loosen the valve seats.**

3. Remove the heated cylinder head from the hot plate and support it with wooden blocks. Drive the exhaust valve guide out of the head from the combustion chamber side.

### CAUTION

**When driving the valve guide out, be careful not to damage the cylinder head.**

4. Remove the new exhaust valve guide from the refrigerator.
5. Install the new exhaust valve guide from the valve spring side of the cylinder head. Drive the exhaust

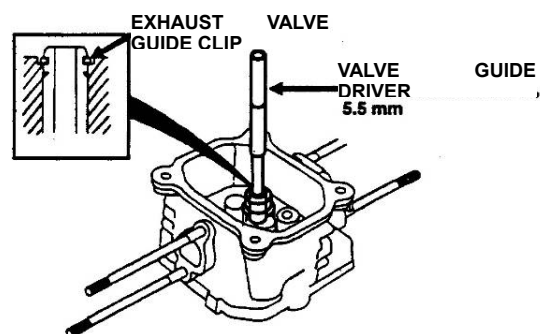
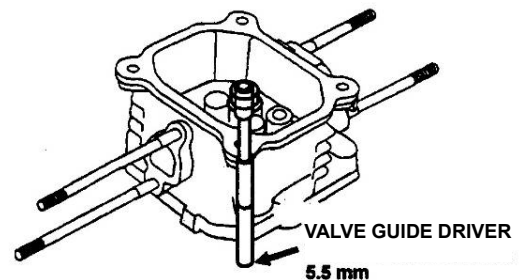
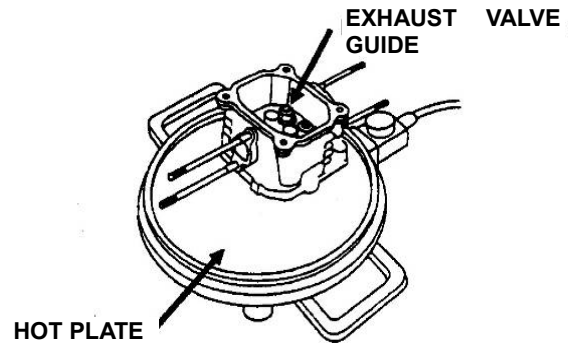

# SECTION 5 Disassembly and Service

valve guide until the clip is fully seated as shown.

6. After installation, inspect the valve guide for damage. Replace the guide if it is damaged.

## Exhaust valve guide reaming

For best results, be sure the cylinder head is at room temperature before reaming the exhaust valve guide.

1. Coat the reamer and valve guide with cutting oil.
2. Rotate the reamer clockwise through the valve guide until the full length of the reamer enters the valve guide.
3. Continue to rotate the reamer clockwise while removing it from the valve guide.
4. Thoroughly clean the cylinder head to remove any cutting residue and dirt.
5. Check the valve guide bore; it should be straight, unobstructed, round and centered in the valve guide. Insert the valve and check operation. If the valve does not operate smoothly, the guide may have been bent during installation. Replace the valve guide if it is bent or damaged.
6. Check the guide-to-stem clearance.

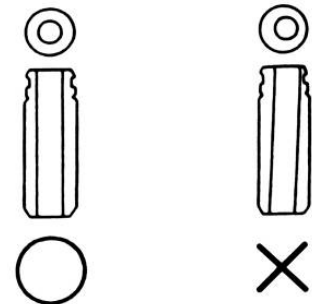
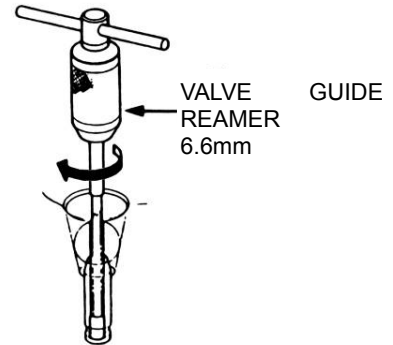

## Valve seat reconditioning

1. Thoroughly clean the combustion chambers and valve seats to remove carbon deposits.
2. Apply a light coat of Prussian blue or erasable felt-tipped marker ink to the valve faces.
3. Insert the valve, and then lift and snap it closely against their seats several times. Be sure the valve does not rotate on the seat. The transferred marking compound will show any area of the seat that is not concentric.
4. Using a 45° cutter, remove enough material to produce a smooth and concentric seat. Follow the valve seat cutter manufacturer's instructions.

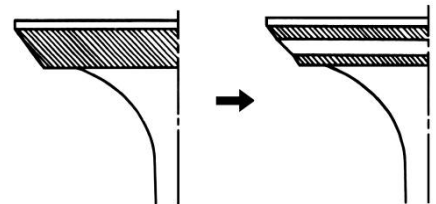

# SECTION 5 Disassembly and Service

**Turn the cutter clockwise, never counterclockwise.**

**Continue to turn the cutter as you lift it from the valve seat.**

5. Using the 30°~32° and 60° cutters to narrow and adjust the valve seat so that it contacts the middle of the valve face.
- The 30°~32° cutter removes material from the top edge. The 60° cutter removes material from the bottom edge. Be sure that the width of the finished valve seat is within specification.

**CONTACT TOO HIGH**

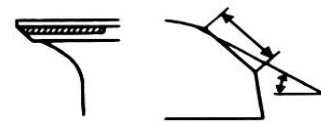

**CONTACT TOO LOW**

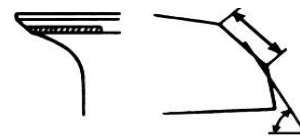

## Valve seat width

Standard	Service limit
0.8 mm~1mm	1.5 mm

1. Make a light pass with the 45° cutter to remove any possible burrs at the edges of the seat.
2. After resurfacing the seats, insert the valve to inspect for even contact with the valve.
3. Apply a light coat of Prussian Blue or erasable felt-tipped marker ink to the valve face.
4. Insert the valve, and then lift and snap it closely against the seat several times. Be sure the valve does not rotate on the seat. The seating surfacing, as shown by the transferred marking compound, should have good contact all the way around.

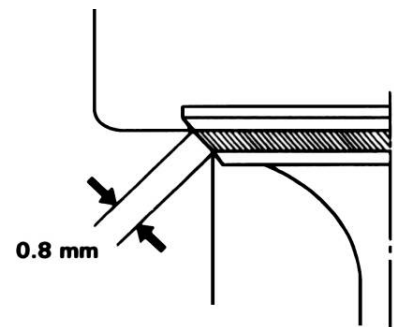

## CAUTION:

**To avoid severe engine damage, be sure to remove all lapping compound from cylinder head before reassembling.**

5. Check the valve clearance after reassembly.

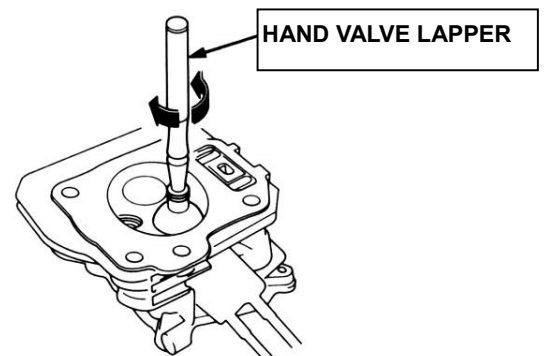

# SECTION 5 Disassembly and Service

## 5-2-7 Crankcase Cover, Governor Gear DISASSEMBLY

- 1) Loosen off the M6×35 bolt, remove the oil filler cap/dipstick, and use a special tool to remove oil filter.
- 2) Loosen off 3 M6×16 bolts, remove oil pump cover, seal ring and take out oil pump assembly.
- 3) Loosen off crankcase cover bolts, remove crankcase and disassemble it.
- 4) Remove governor slider, governor shaft, governor gear, oil strainer, crankcase cover bearing and oil seal.

### Precautions for reassembly:

- 1) Align the square tab under the oil pump rotor with the slot in the camshaft's upper end, position inner rotor into the hole in crankcase cover; position outer rotor into the hole in crankcase cover.
- 2) When installing the bearing, let its side with letters face upward; use a special tool to press it in.
- 3) After installing governor kit, confirm governor gear can rotate easily, governor weights can smoothly move apart from each other. Use a feeler gauge to check gear clearance (standard: 0.05~0.35mm).

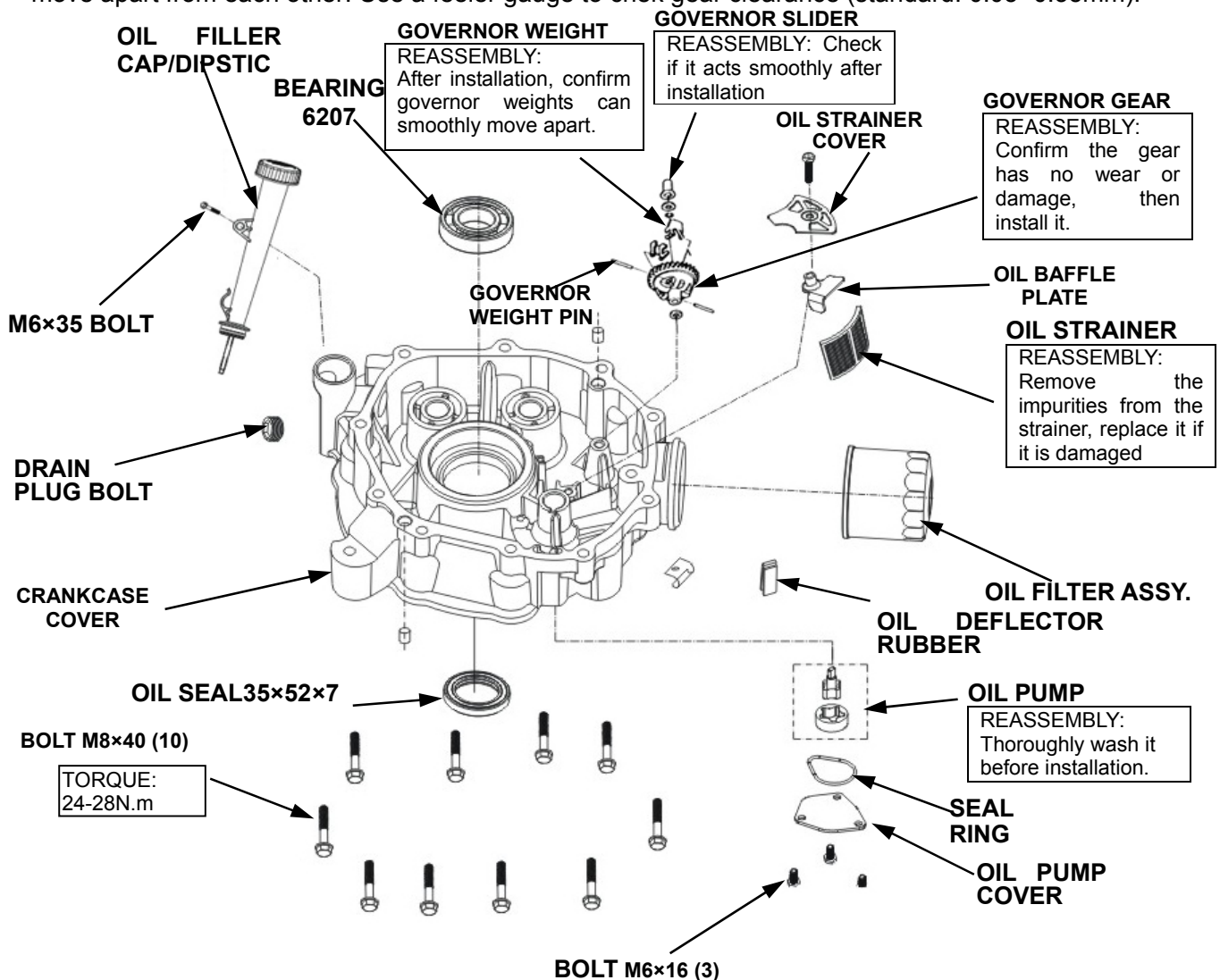

# SECTION 5 Disassembly and Service

## 5-2-8 Crankcase, Crankshaft, Piston

### DISASSEMBLY

- 1) Loosen off 2 M6×12 bolts, remove breather chamber cap, breather chamber packing, then loosen off 1 M6×12 bolt, remove the reed valve.
- 2) Remove balancer weight A, balancer weight B, camshaft, and valve lifters.
- 3) Loosen off connecting rod bolts, remove connecting rod cap, crankshaft, governor arm shaft, connecting rod, piston, piston rings, etc.

### Precautions for reassembly:

- 1) Reed valve should be positioned at opening of oil passage, and should not be wrongly positioned.
- 2) When installing piston, piston rings, and piston pin clip, note the installing directions as per the installation requirement.
- 3) Ensure alignment of punch marks when installing crankshaft, balancer weight and camshaft.

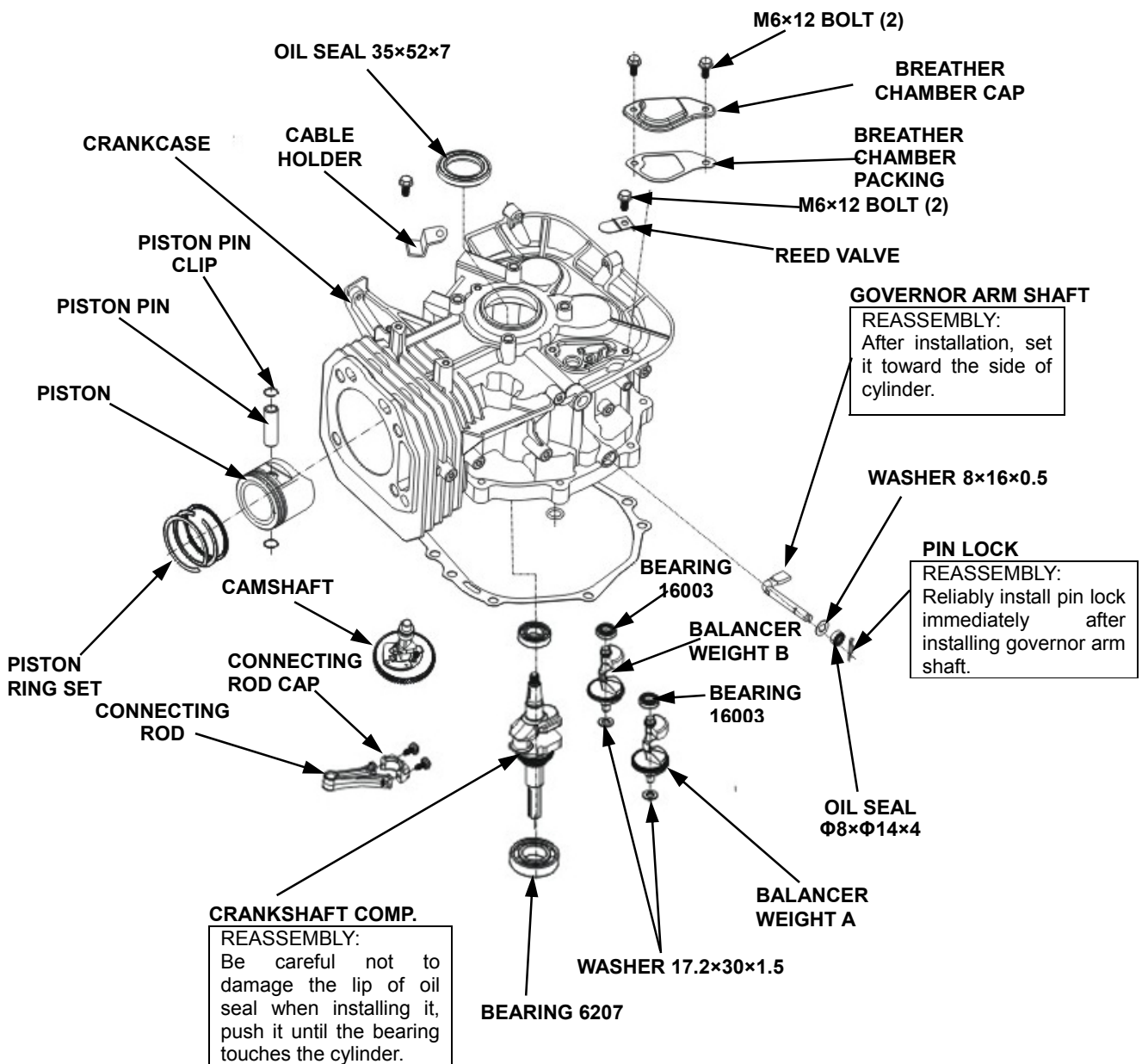

# SECTION 5 Disassembly and Service

## 2. Piston / Piston ring

**REASSEMBLY:**

- 1) Install all rings with the markings facing upward.
- 2) Be sure that top and second rings are not interchanged.
- 3) Check that the rings rotate smoothly after installation.
- 4) Space the piston ring end gaps 120 degrees apart, and do not align the gaps with the piston pin.

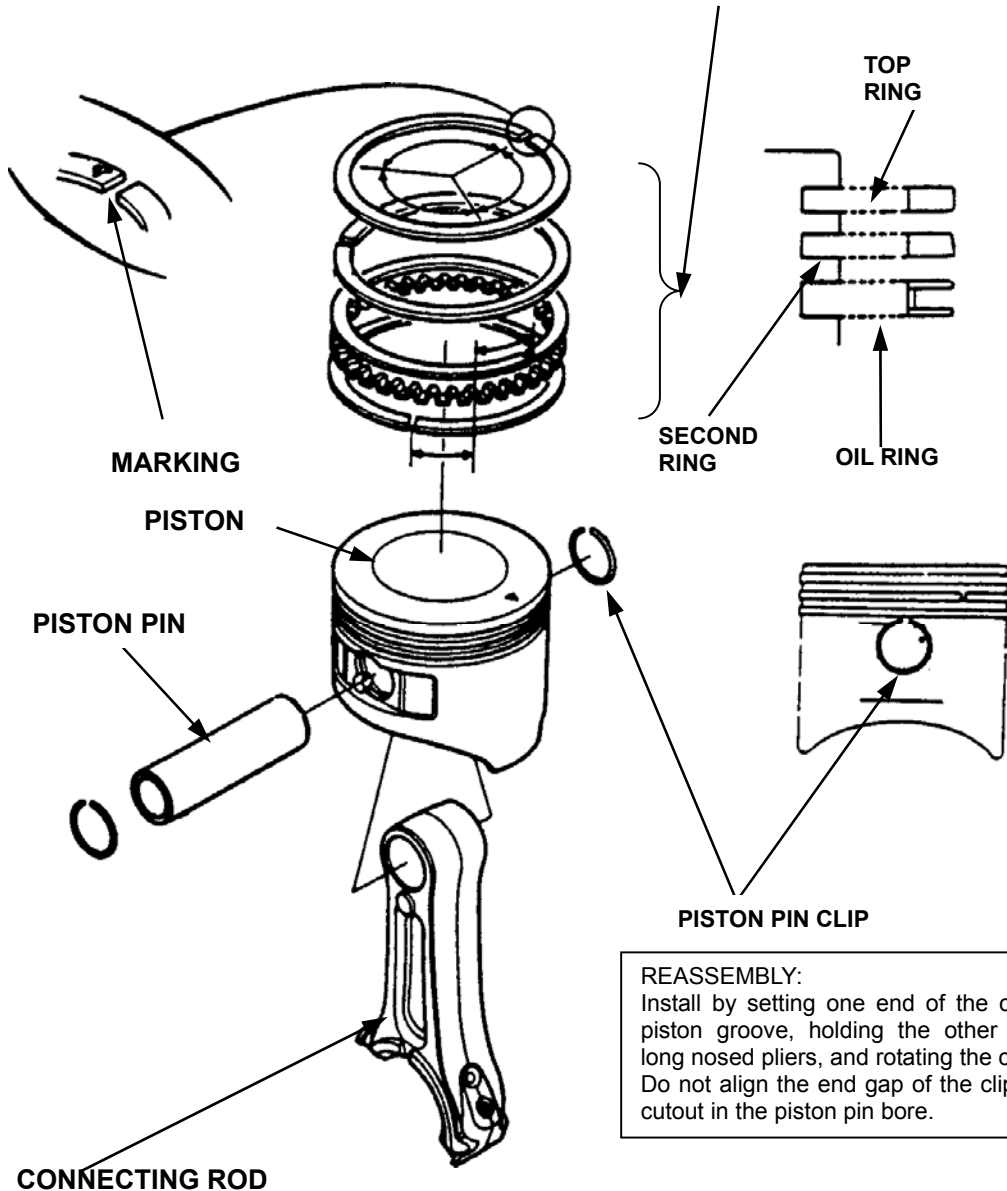

**REASSEMBLY:**

Install by setting one end of the clip in the piston groove, holding the other end with long nosed pliers, and rotating the clip in. Do not align the end gap of the clip with the cutout in the piston pin bore.

**REASSEMBLY:**

Install the connecting rod with the long end toward the triangle marked side of the piston.

# SECTION 5 Disassembly and Service

## Valve timing

After installing the crankshaft, align the punch marks on the timing gears.

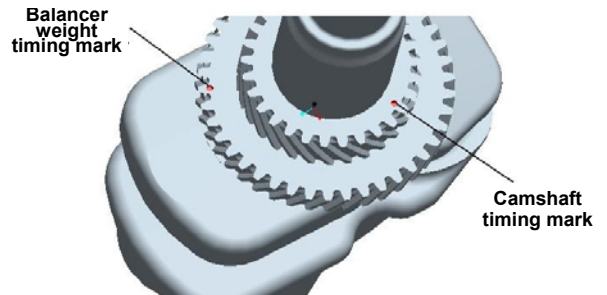

## TIMING GEAR

### DISASSEMBLY:

1. Scribe a line on the crankshaft and the timing gear tooth as shown.
2. Use a hydraulic press and a commercially

### REASSEMBLY:

- 1) Using the old gear for reference, scribe a line at the same position on the new timing gear tooth.
- 2) Use a hydraulic press and the special tool to press the timing gear in with the scribed marks aligned.

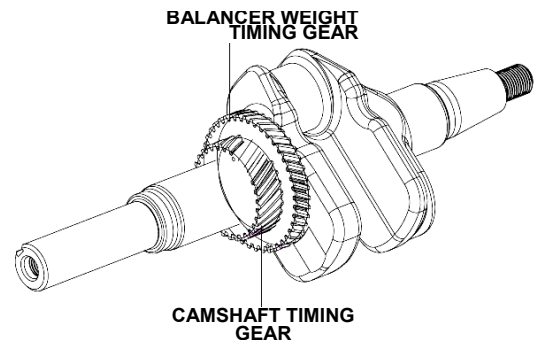

### CAUTION:

*Do not scribe the crankshaft too deep. Otherwise, oil may seep through the oil seal.*

## CRANKSHAFT, CAMSHAFT, BALANCER

### ASSEMBLY:

1. Be careful not to damage oil seal when installing camshaft, push crankshaft in until the bearing touches the cylinder. Then install the valve lifters in the crankcase.

2. Align the punch marks on camshaft gear and timing gear (the small gear of the crankshaft) when installing the crankshaft.

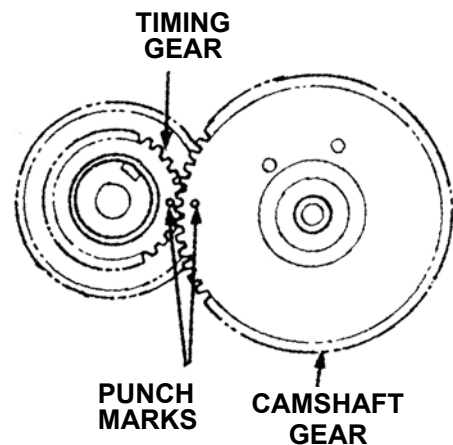

3. Align the punch marks on balancer gear and balancer drive gear (the big gear of the crankshaft) when installing Balancer A.

### CAUTION:

*Don't confuse Balancer A and Balancer B (Balancer A's gear has two punch marks.)*

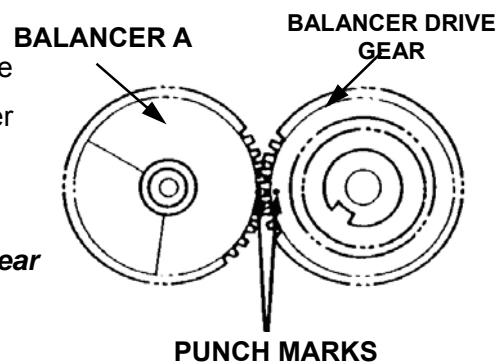

# SECTION 5 Disassembly and Service

4. Align the punch marks on Balancer A and Balancer B when installing Balancer B.

After installation, check whether camshaft, crankshaft, Balancer A, and Balancer B are installed in proper positions, and can rotate easily.

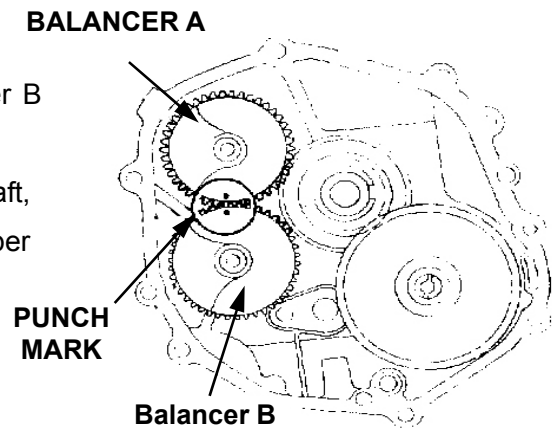

## INSPECTION

### CRANKSHAFT BEARING FREE PLAY

1. Clean the bearing in solvent and dry it.
2. Spin the bearing by hand and check for play. Replace the bearing if it is noisy or has excessive play.

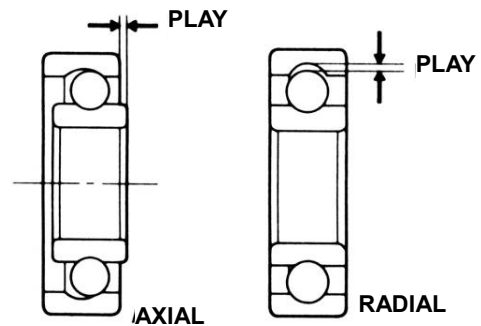

### PISTON PIN OD

Standard	Service limit
19.992~19.998 mm	19.9 mm

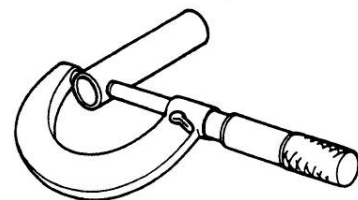

### CYLINDER I.D.

Measure and record cylinder I.D. at three levels in both "X" axis (perpendicular to crankshaft) and "Y" axis (parallel to crankshaft). Take the maximum reading to determine cylinder wear and taper.

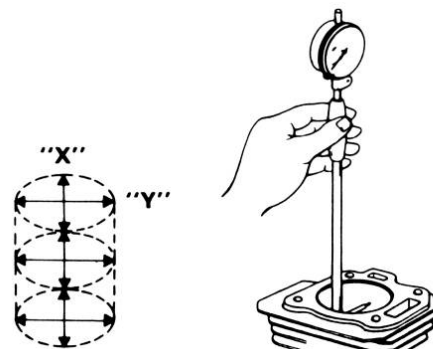

Model	Standard	Service limit
1P88F-1	X: 88.0~88.01 mm	88.1 mm
	Y: 88.0~88.01 mm	88.1 mm
1P90F-1	X: 90.0~90.01 mm	90.1 mm
	Y: 90.0~90.01 mm	90.1 mm
1P92F-1	X: 92.0~92.01 mm	92.1 mm
	Y: 92.0~92.01 mm	92.1 mm

# SECTION 5 Disassembly and Service

## PISTON AND PISTON RINGS

Inspect contact between piston and piston rings, defects of piston grooves, burn, cracks and other defects on piston top. If the damage is severe (such as brokage), replace the damaged part.

Removal of carbon deposit

Carbon deposits gather on piston top and upper edge of cylinder. Remove all carbon deposits before inspection. Use kerosene to drench carbon deposits, then use a blunt scraping knife or a wire brush to remove carbon deposits.

## PISTON SKIRT O.D.

Measure and record piston skirt O.D. at a point 10mm from bottom of the skirt 90° to the piston pin bore.

Model	Standard	Service limit
1P88F-1	87.965mm~87.975mm	87.940 mm
1P92F-1	89.965mm~89.975mm	89.940 mm
1P92F-1	91.960mm~91.975mm	91.940 mm

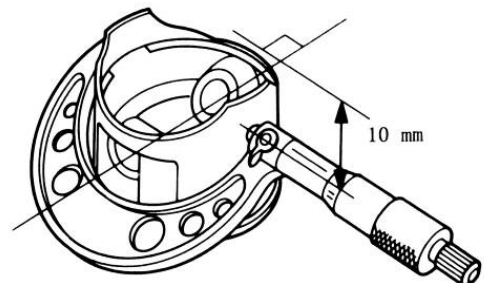

## PISTON-TO-CYLINDER CLEARANCE

Difference between cylinder's maximum diameter and piston skirt O.D. is the piston-to-cylinder clearance.

Standard	Service limit
0.025-0.045 mm	0.055 mm

## PISTON RING SIDE CLEARANCE

Standard	Service limit
0.02~0.06 mm	0.011 mm

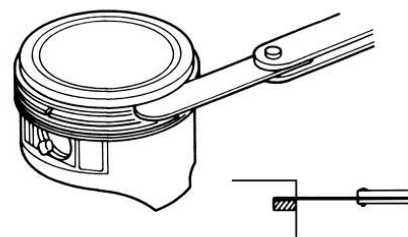

## PISTON RING WIDTH

	Standard	Service limit
Top	1.17mm~1.19mm	1.1 mm
Second	1.47mm~1.49mm	1.4 mm
Oil	2.68mm~2.78mm	2.5 mm

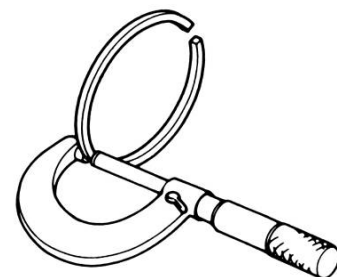

# SECTION 5 Disassembly and Service

## PISTON RING END GAP

	Standard	Service limit
Top	0.15mm~0.30mm	1.0 mm
Second	0.25mm~0.40mm	1.0 mm

Before measuring ring end gap, use the piston top to position the ring so it will not be cocked in the cylinder bore.

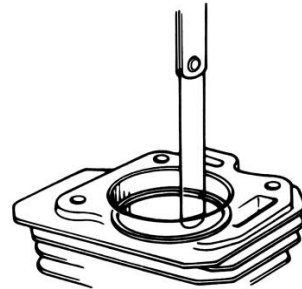

## Inspection of connecting rod

If the connecting rod is bent or twisted, or its big end's bearing bush and small end shaft housing's outer ring has play, or one of its sides has cracks, the connecting rod must be scrapped and replaced with a new one.

## CONNECTING ROD SMALL END I.D.

If it is smaller than standard, or beyond service limit, replace the connecting rod.

Standard	Service limit
20.007mm~20.018 mm	20.02 mm

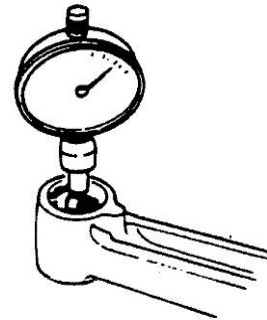

## CONNECTING ROD BIG END I.D.

If it is smaller than standard, or beyond service limit, replace the connecting rod.

Standard	Service limit
36.015mm-36.025 mm	36.03 mm



## CRANKPIN O.D.

Standard	Service limit
35.966mm~35.981 mm	35.946mm

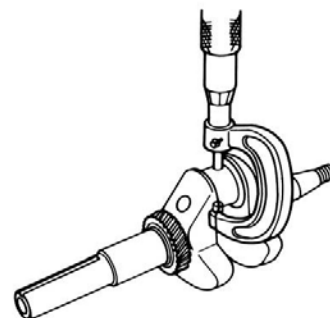

# SECTION 5 Disassembly and Service

## CONNECTING ROD BIG END SIDE CLEARANCE

Standard	Service limit
0.025mm~0.35mm	0.4 mm

## CONNECTING ROD BIG END OIL CLEARANCE (RADIAL)

- 1) Clean all oil from crank pin surface and its inner side.
- 2) Place a piece of plastigauge on crank pin, install connecting rod, and tighten the bolts to the specified torque.

**Tightening torque: 17.5 N·m**

### NOTE

Do not rotate crankshaft when tightening the connecting rod bolts.

- 3) Remove the connecting rod and measure the plastigauge thickness.

Standard	Service limit
0.040-0.063 mm	0.083mm

- 4) If the clearance exceeds the service limit, replace the connecting rod and recheck the clearance. If clearance still exceeds service limit after using the new connecting rod, lap the crank pin to recondition it, and use a connecting rod smaller than the standard value.

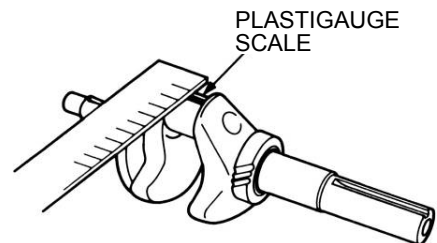
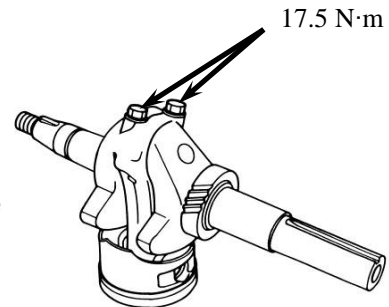
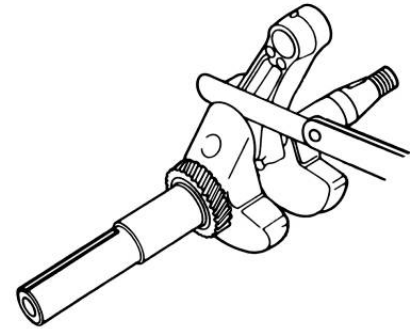

## CAMSHAFT

As the main driving piece of the gasoline engine's valve actuating mechanism, the camshaft controls opening and closing of intake and exhaust valves following a regular rule. Check cam surface and cam height for damage, check whether camshaft and bearings have play or are worn, if so, replace all of them.

# SECTION 5 Disassembly and Service

---

## CAM HEIGHT

	Standard	Service limit
IN	32.563mm~32.603m m	Replace if smaller than 32.4 mm
EX	32.049mm~32.099m m	Replace if smaller than 31.9 mm

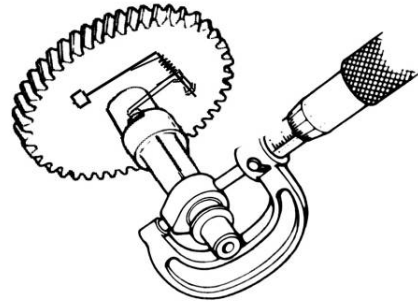

## CAMSHAFT O.D.

Standard	Service limit
15.966m m~15.984mm	15.946 mm

**Note the location of the decompression mechanism, check to be sure it moves freely.**

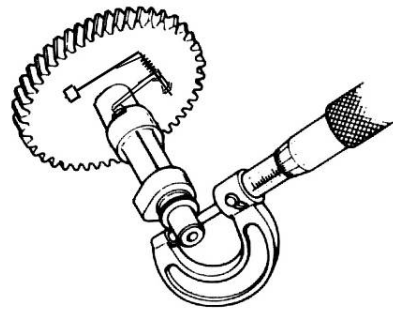

# Other ManualsLib Projects



[www.manualslib.com](http://www.manualslib.com)



[www.manualslib.de](http://www.manualslib.de)



[www.manualslib.es](http://www.manualslib.es)



[www.manualslib.fr](http://www.manualslib.fr)



[www.manualslib.nl](http://www.manualslib.nl)



[www.manualslib.mx](http://www.manualslib.mx)



[www.manualslib.tech](http://www.manualslib.tech) 30+ Languages