

# Owner's Manual

**2V90FD**  
**2V80FD**

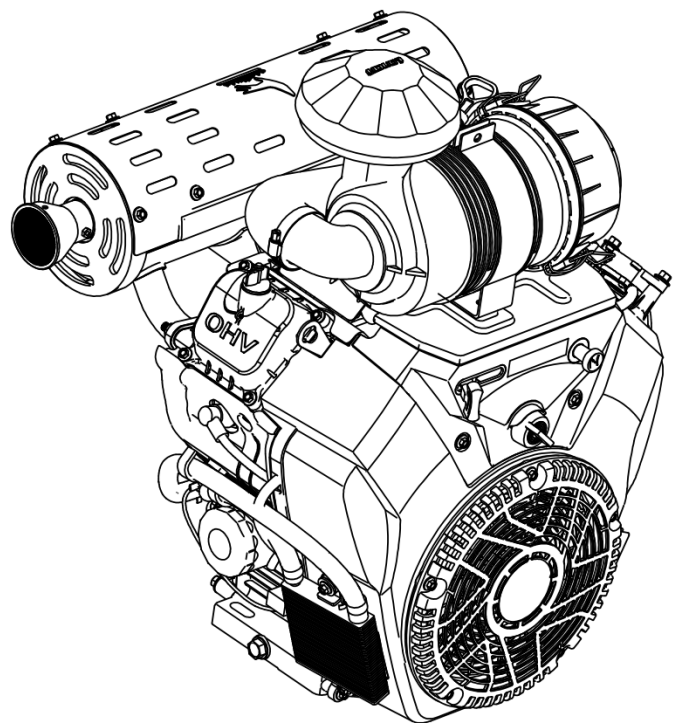
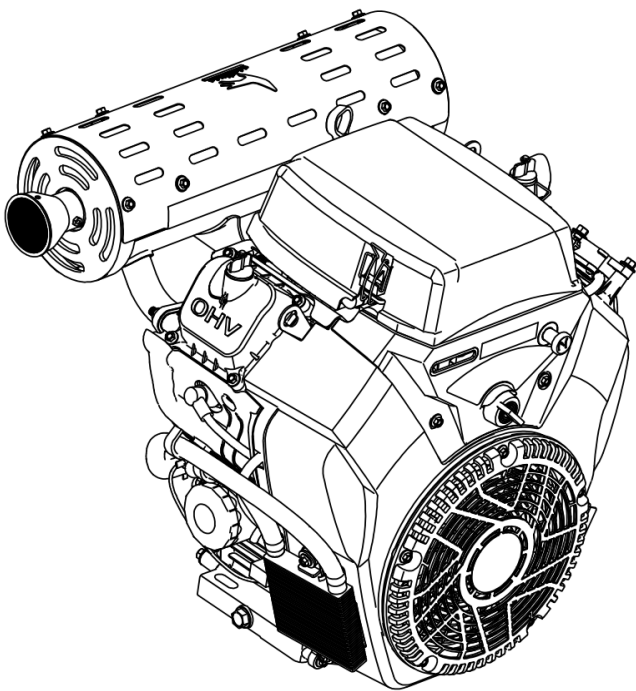

Thank you for your purchasing our Engine.

Please keep this manual in proper place so as to read it for reference at any time.

Take this manual as a part of the engine. If the engine is resold, it is required to transfer the engine with the manual.

Our abides by the continuous development strategy; therefore, our reserves the right of modification of product and revision of the manual without any notice.

Copy right our company All rights reserve.

It is prohibited from reproducing, transferring, distributing and memorizing any content in the manual without obtaining a written approval from our General-purpose Engine Co in advance.

## **Contents**

## Contents

---

|                                  |    |
|----------------------------------|----|
| 1.Safety.....                    | 2  |
| 2.Parts and component names..... | 3  |
| 3.Use of engine.....             | 6  |
| 4.Check before operation.....    | 8  |
| 5.Start engine.....              | 11 |
| 6.Stop engine.....               | 14 |
| 7.Maintenance .....              | 16 |
| 8.Engine storage.....            | 22 |
| 9.Troubleshoot.....              | 24 |
| 10.Battery.....                  | 27 |
| 11.Engine parameters.....        | 28 |
| 12.Wiring diagram.....           | 29 |

### 1. Safety

#### Consumers' responsibility

- Before operating the engine, it is required to read the manual carefully and understand it, otherwise hurt to body or damage to engine may occur.
- Be familiar with controlling and operating the engine and emergency stop, it is only allowed to operate the engine by authorized person.
- Children are not allowed to operate the engine on no account and children and pets must be far away from the operating site. .

#### Caution for filling fuel

- Petrol has an extreme inflammability. Fill fuel in opening air and in good ventilation condition, the engine is stopped.
- Prohibit smoking, keep flame away from naked flame and spark while filling fuel.
- Do not start engine while the splashed petrol drips remain.

#### Hot exhaust

- When the engine works, the muffler is heated to high temperature, even the engine stopped after a while. Be careful to keep your hand beyond the touch with the muffler. Do not store the engine in room till it is cool.
- To prevent fire, keep the engine 1m away from the wall or other devices. And of course, the inflammable substance should be placed further away from the working engine.

#### Carbon monoxide intoxication

- The emission from the engine contains toxic carbon monoxide, avoid absorbing the emission in.
- Do not operate the engine in enclosed cabinet or in poor ventilation condition.

2. Part and component names

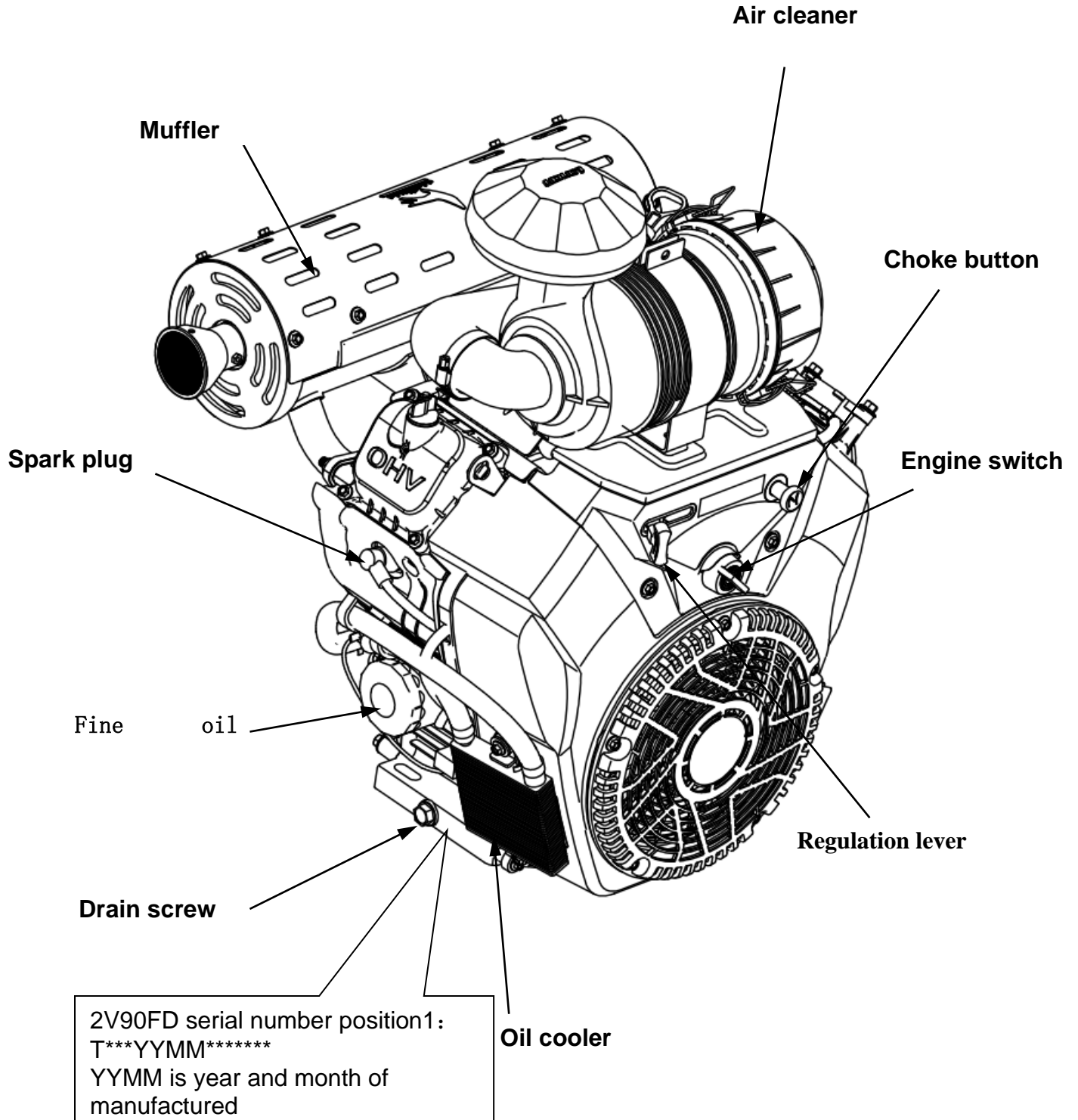

# Use of Engine

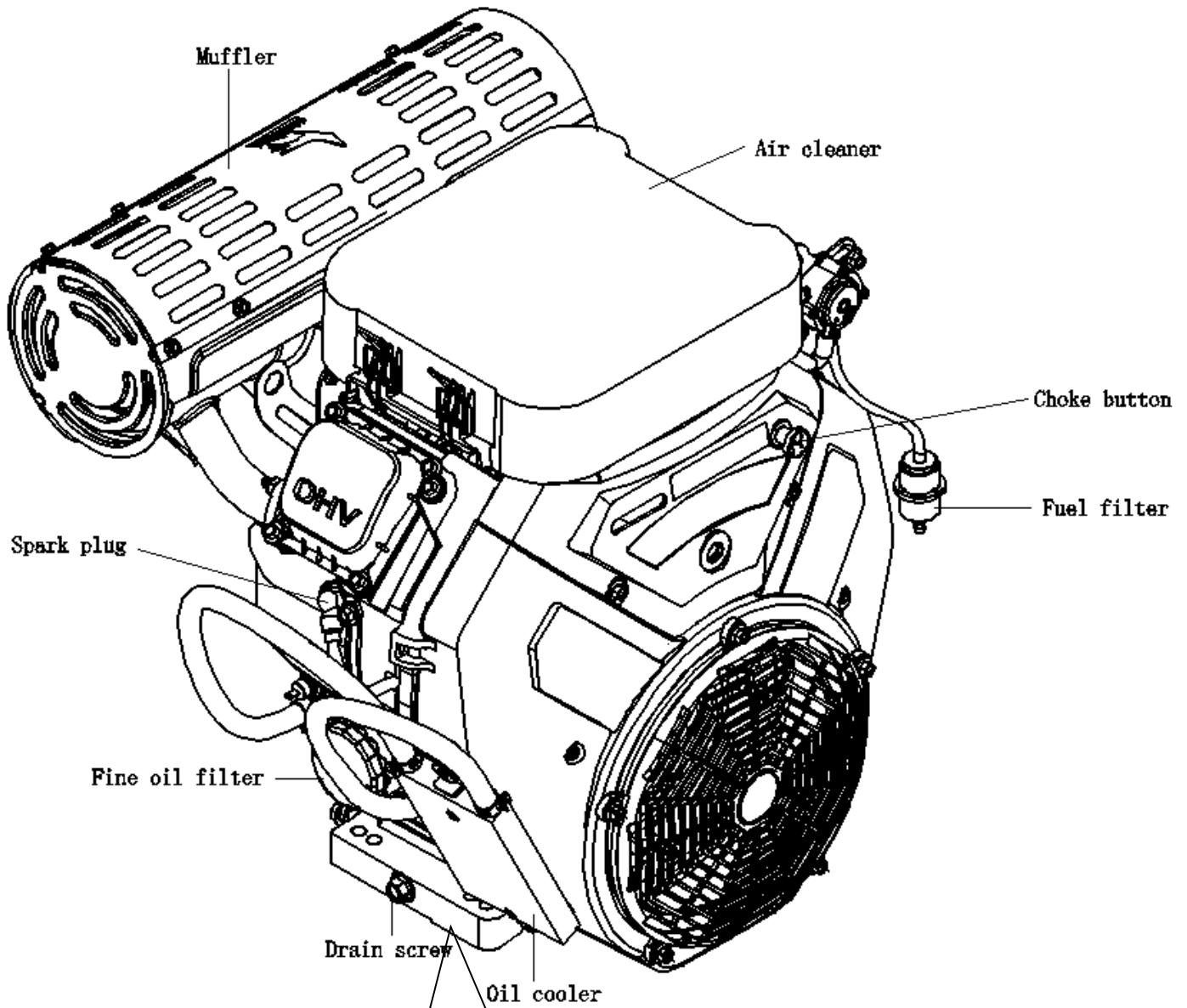

2V90 Serial number  
position1:  
T\*\*\*YYMM\*\*\*\*\*  
YYMM is year and month of  
manufactured

## Use of Engine

---

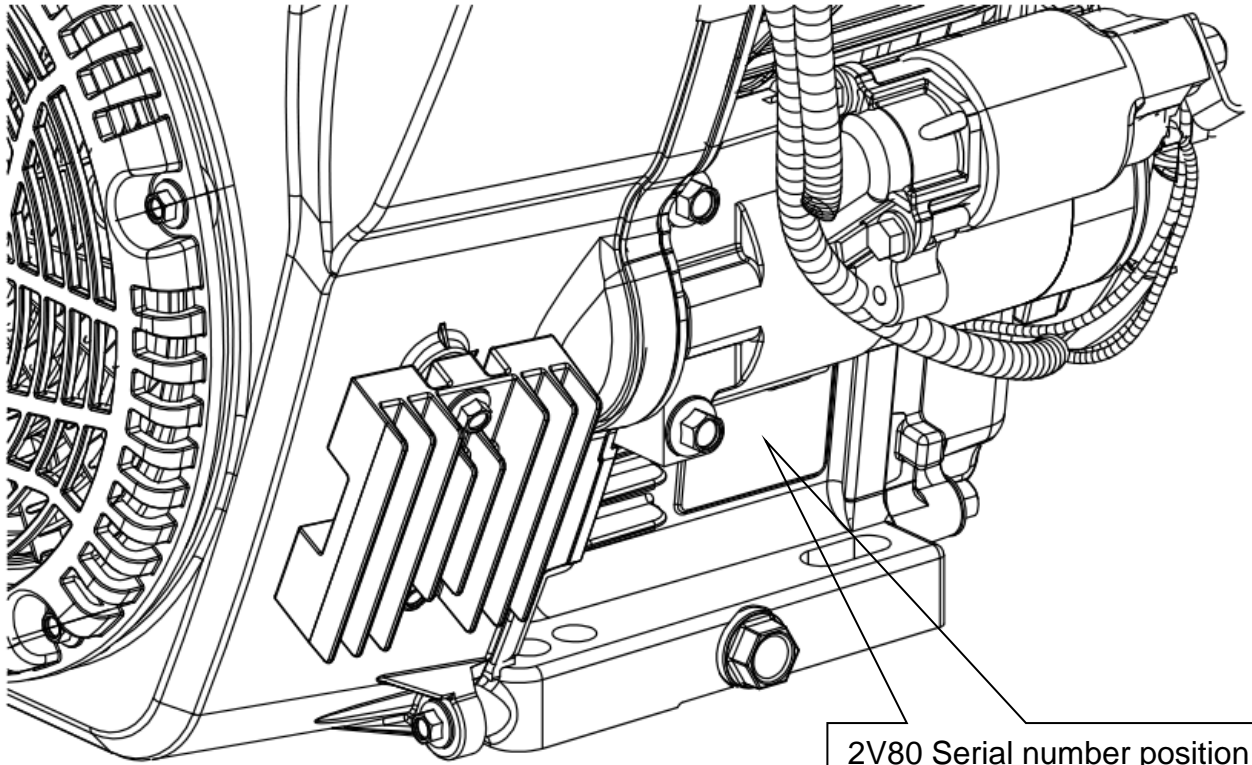

2V80 Serial number position  
2:  
T\*\*\*YYMM\*\*\*\*\*  
YYMM is year and month of  
manufactured

## 3. Use of engine

### 1) Engine switch

The engine switch is a ignition circuit for starting and stopping engine. When the engine switch turns to “on” position, the engine runs, when the switch turns to “off” position, the engine stops.

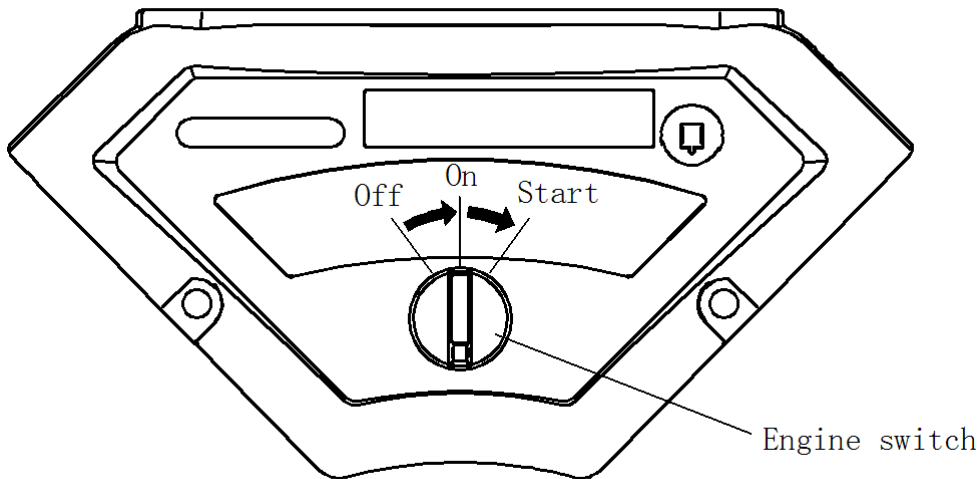

### 2) Choke button

The function of the choke button is to open or close the choke valve in the carburetor. When pull out the button, the choke valve is closed, in such case, it is prone to start the cold engine. When the engine works normally, it is required to push the choke button in, that is to say the choke valve is in opening position,

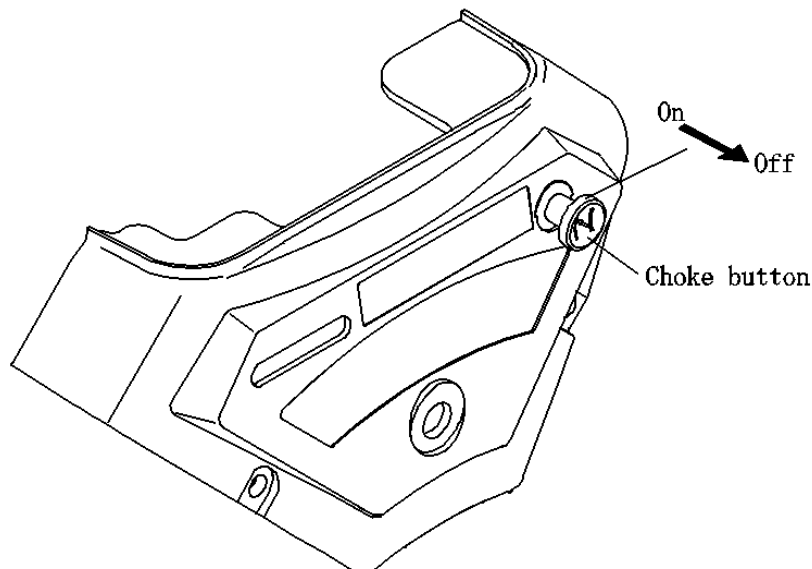

### 3) Regulation lever

Regulate the position of the regulation lever to get the desired speed.

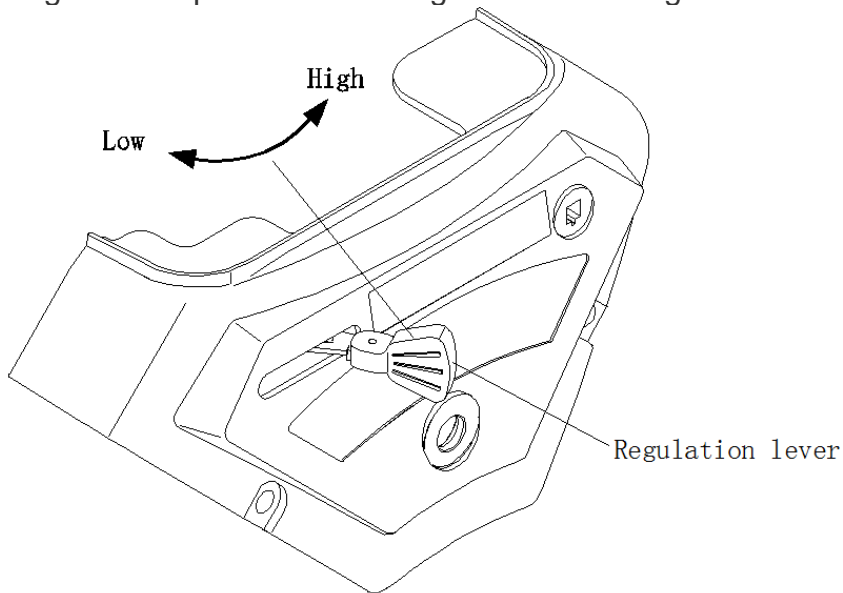

For a reasonable speed of the engine, please refer to indicated parameters of the matched device.

### 4) Engine protecting system

The engine protecting system is designed to protect engine from damage because of lack of oil in the crank case. When the engine oil is lower than the safe level line, the engine protecting system will work to stop the engine automatically (the engine switch is still in "on" position).

If the engine stops automatically but can not start again, first of all, check the oil level, if fault remains, do other inspection.

## 4. Check before operation

### Routine inspection

- Observe the leakage of engine oil and fuel.
- Observe damage.
- Check guard cover and cap position, and the tightness of screw, bolt and nut.

### Check engine oil

**Caution** After stalling, place the engine in level position, then check oil level.

- 1) Pull out the oil ruler and clean it.
- 2) Plug in the ruler thoroughly and take it out again to check the oil level.
- 3) If the oil level is lower than the low limit, remove the filler cap and fill the recommended oil till it goes up to the top limit.
- 4) After filling, keep in mind to reinstall the ruler and tighten the cap.

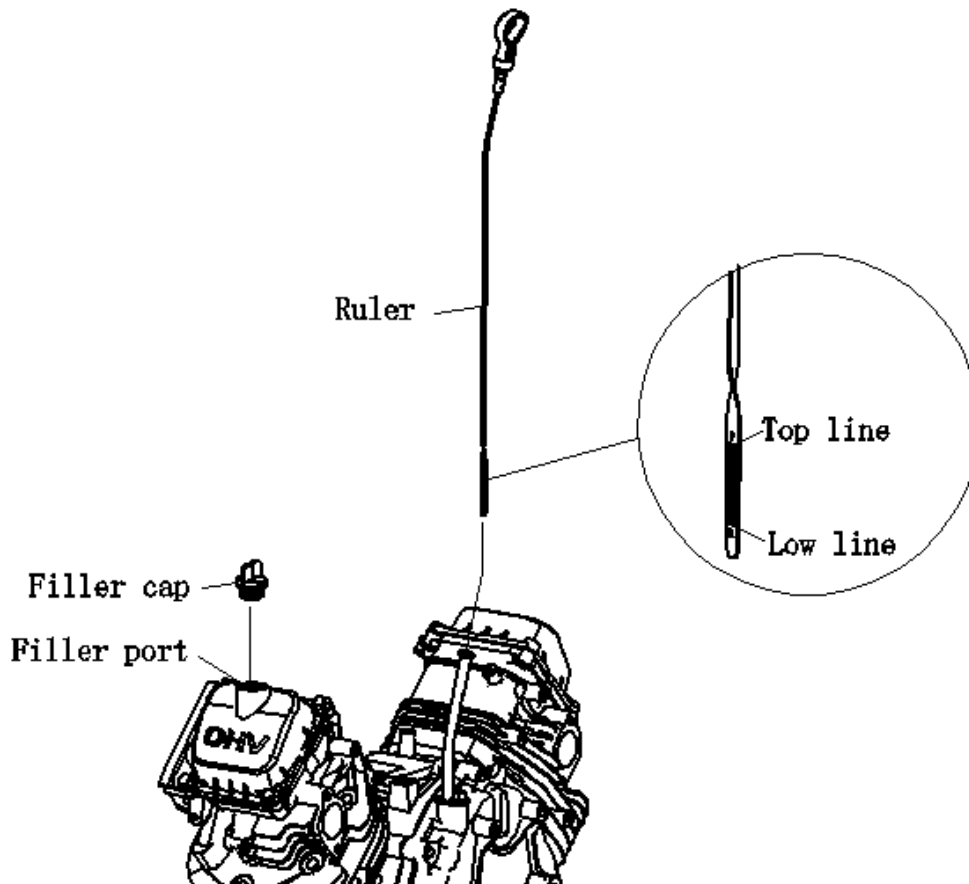

## Check before Operation

---

When the engine oil level is lower than the safe line, the engine protecting system will stop the engine automatically. To avoid engine stalling accidentally, check the oil level before starting the engine each time.

### Caution

When filling fuel, the fuel level does not exceed shoulder of fuel filter (i.e. top level).

It is recommended to fill lead free petrol, grade No 90 or higher.

When use lead free petrol, carbonized dirt is less, thus it can prolong the service life of exhaust system.

It is prohibited to use waste fuel, contaminated fuel and fuel mixed with engine oil.

### Check air cleaner

Remove the air cleaner case to check the element, clean or replace, if necessary.

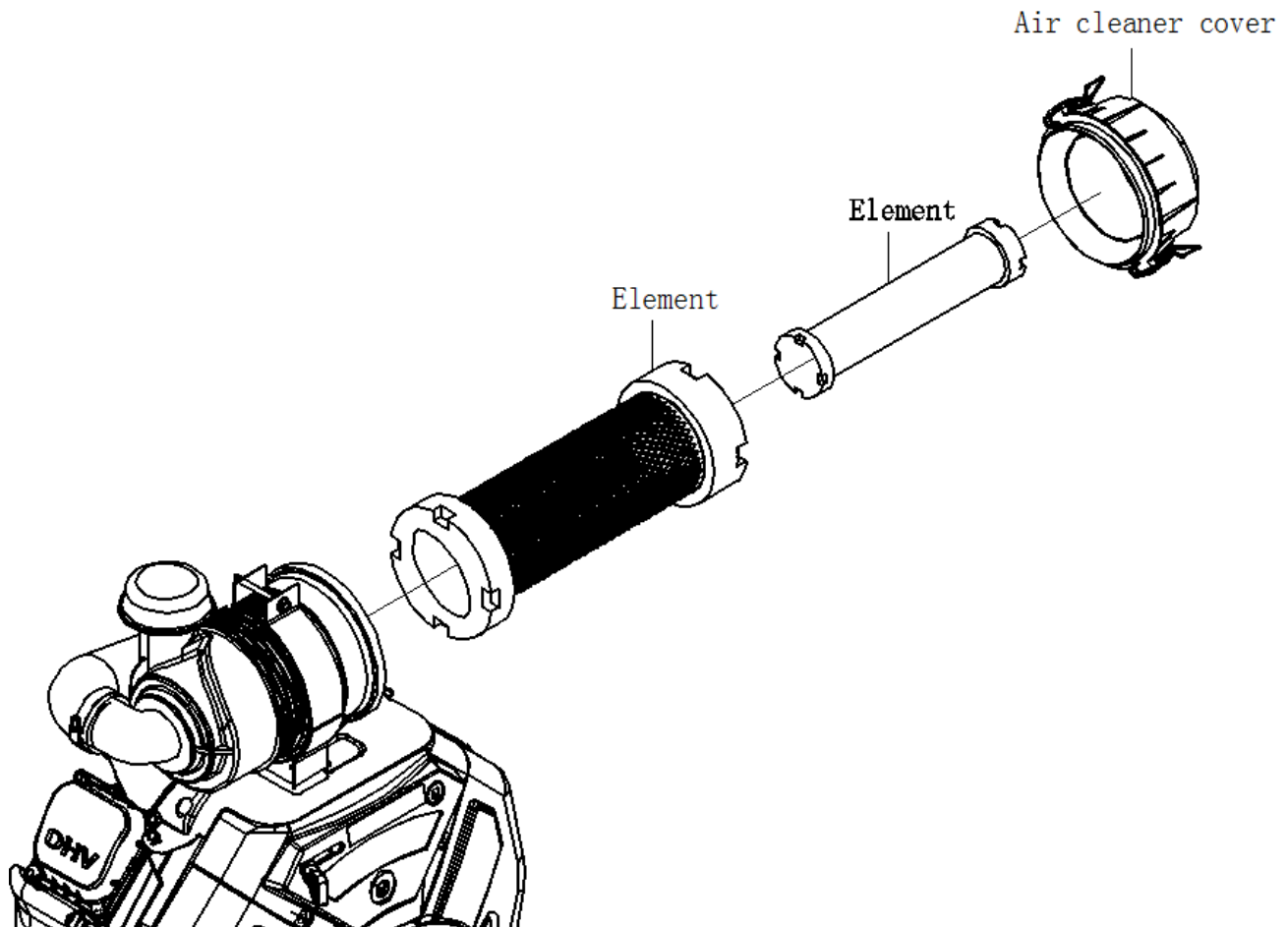

## Check before Operation

---

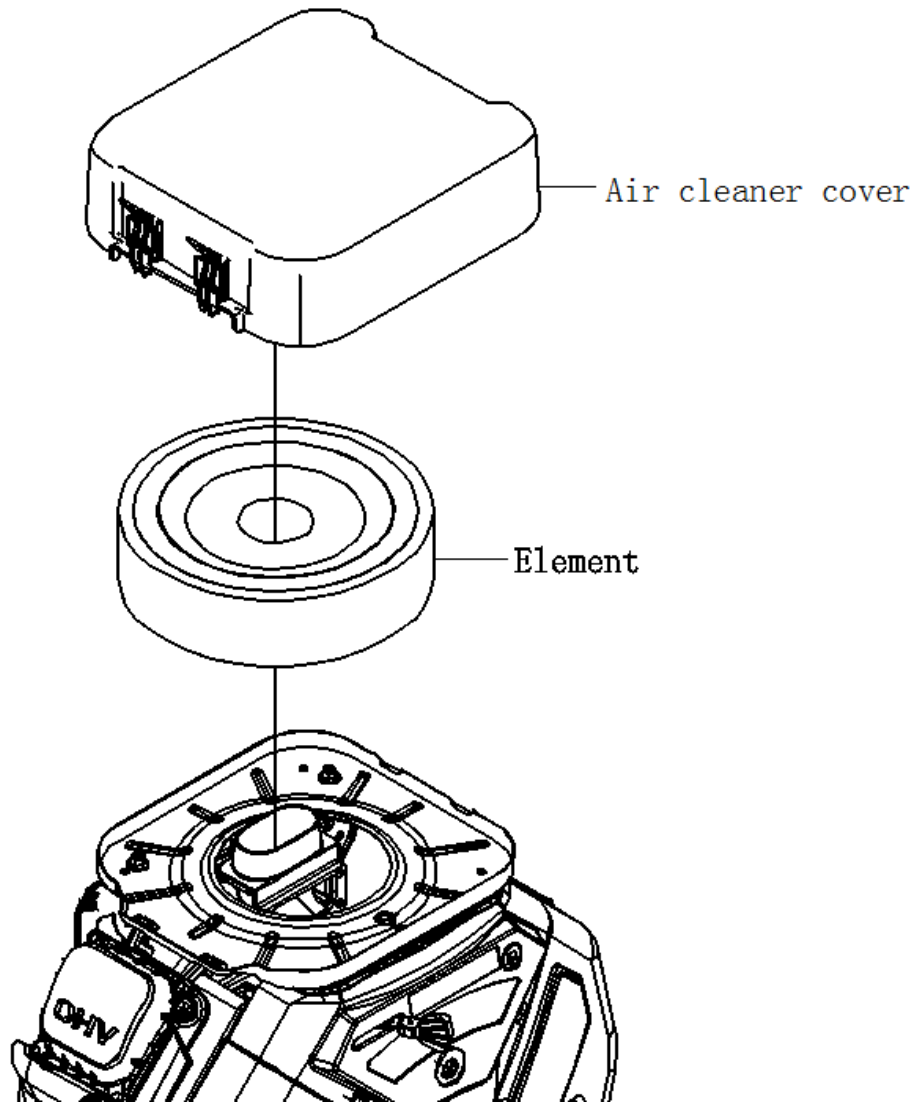

## 5. Start Engine

- 1) When coldstart is performed, the choke button must be “off” position. When hotstart is done, the choke button must be “on” position.

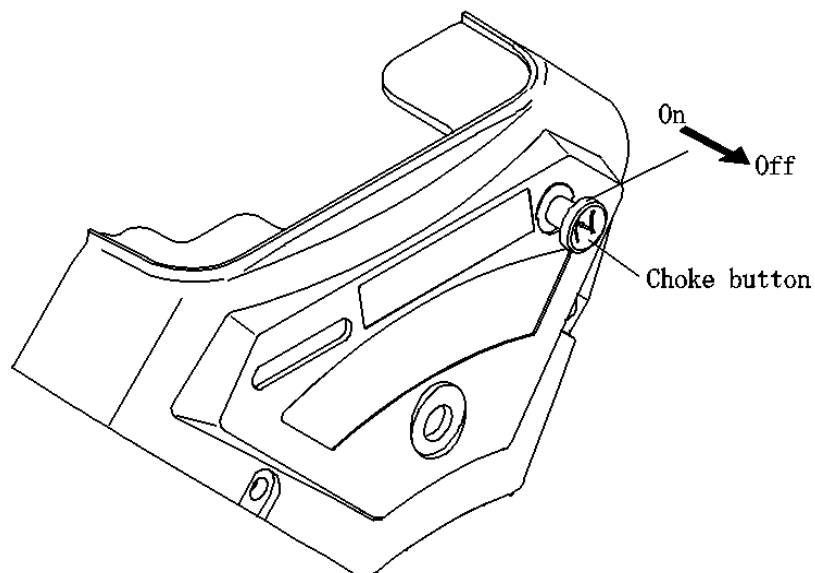

- 2) Regulate the position of the regulation lever from “low ” to “high ” .

- 2V90FD

Engine

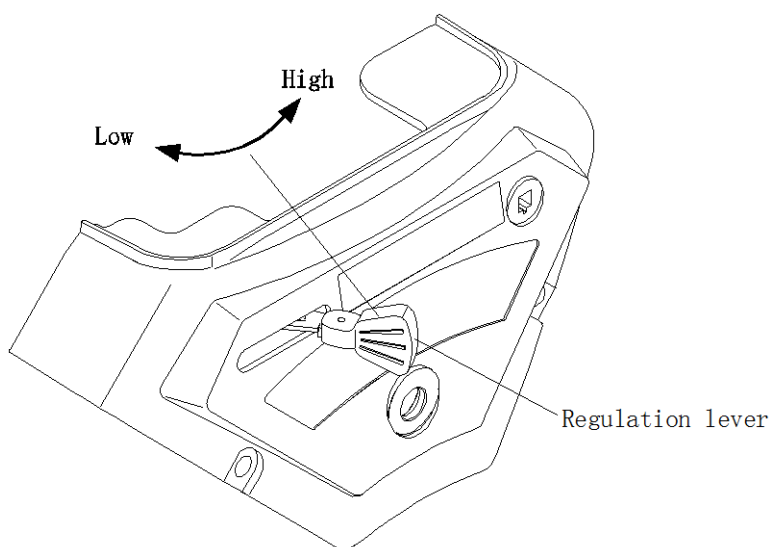

Generator

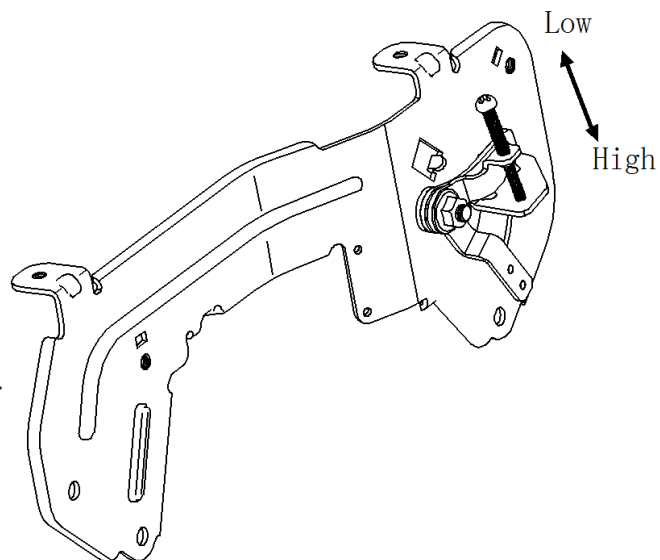

# Start Engine

- 2V80FD

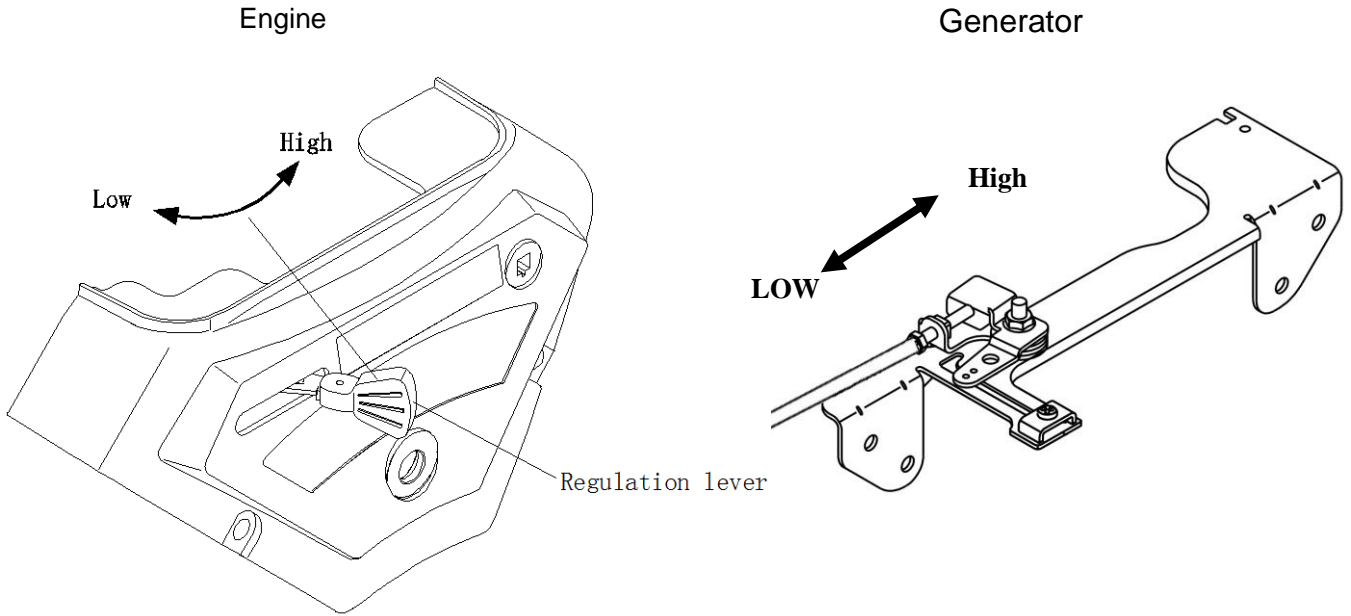

- Generator of digital turn regulating

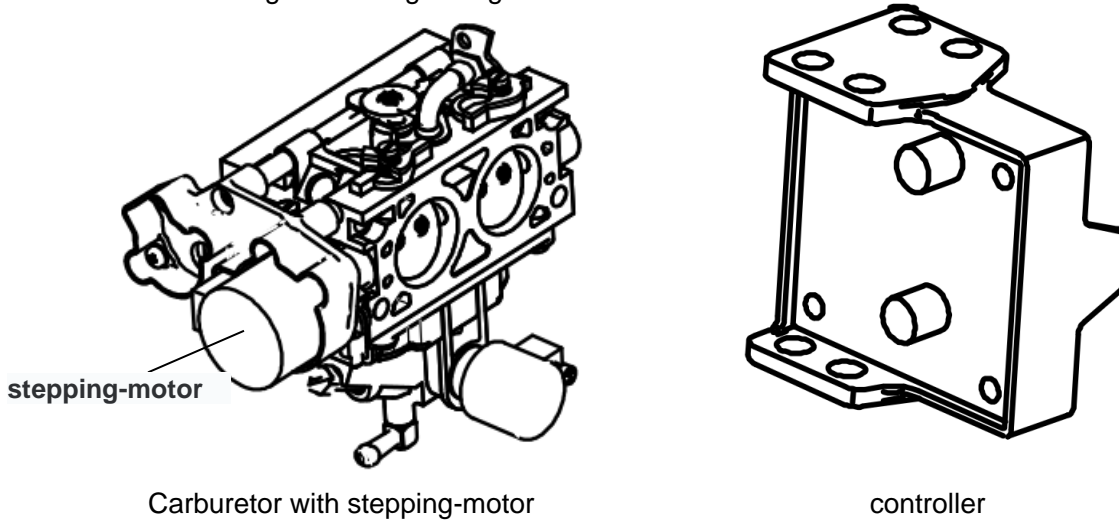

Use program which is setted up in controller to control stepping-motor in carburetor, and then stepping-motor can control valve opening so that the engines can work in fixed speed. People can not adjust engine speed to manual operation.

# Start Engine

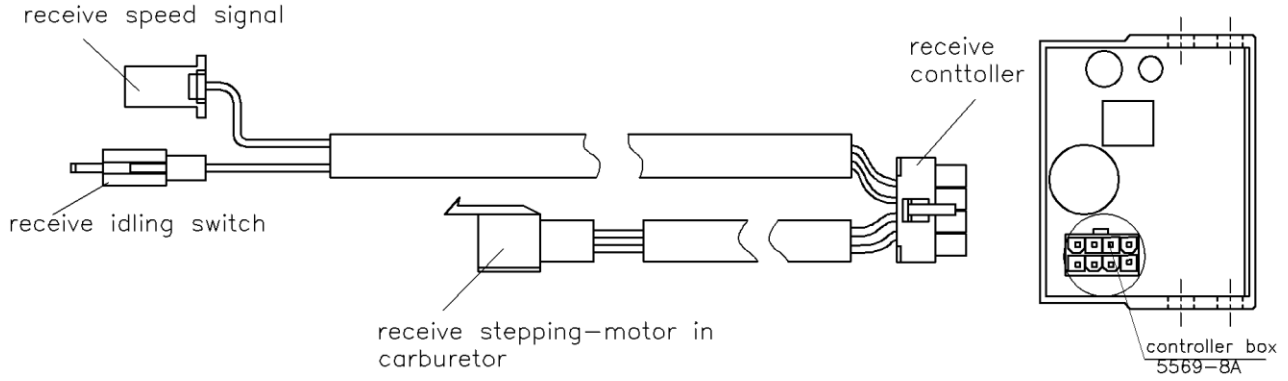

3) Turn the engine switch to "on" position.

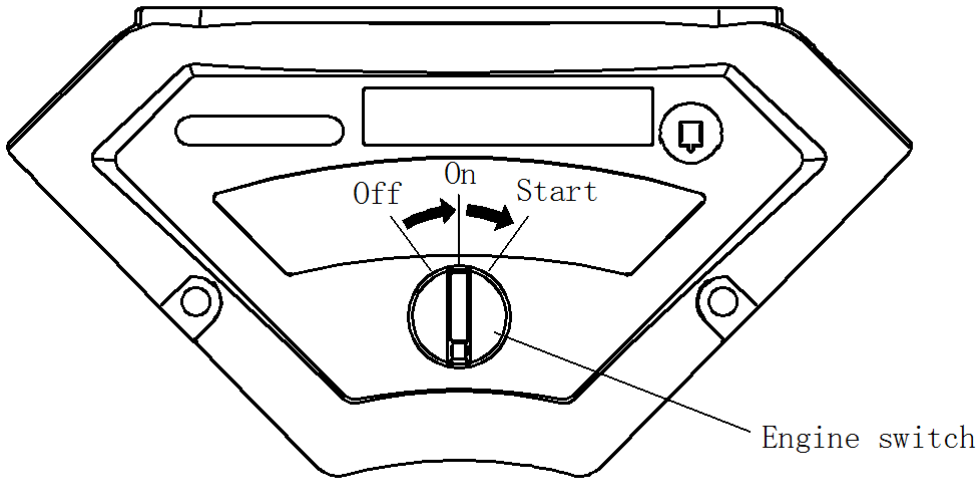

4) If the engine starts in the condition that the choke button is pulled to "off" position, when the engine warming up, push the choke button gently to "on" position. If hot start is done, the choke button is kept in "on" position.

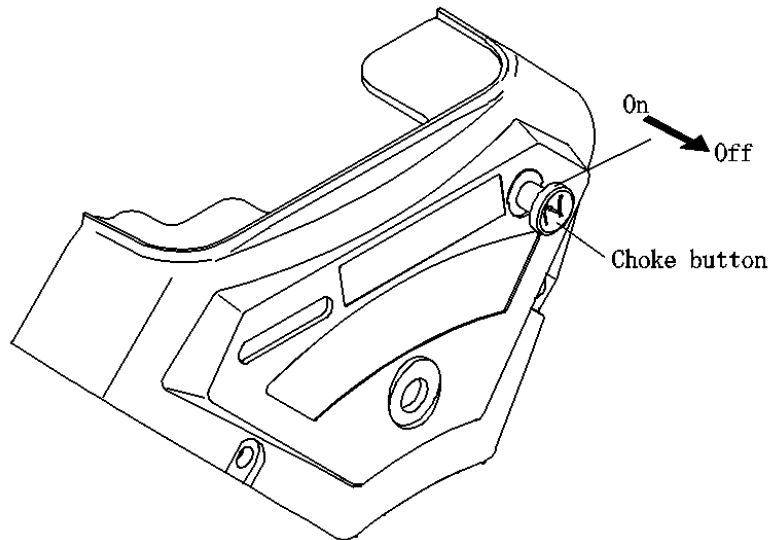

## 6. Stop engine

In emergency, it is an easy way to stop the engine, just turn the engine switch to “off”.  
But as a rule, stop engine as follows:

1) Turn the regulation lever to “low” position.

- 2V90FD

Engine

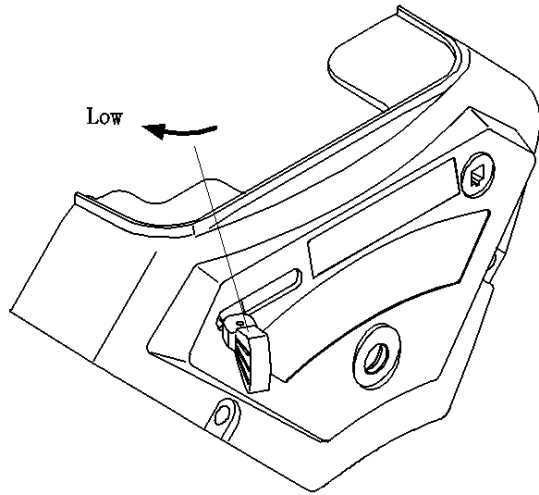

Generator

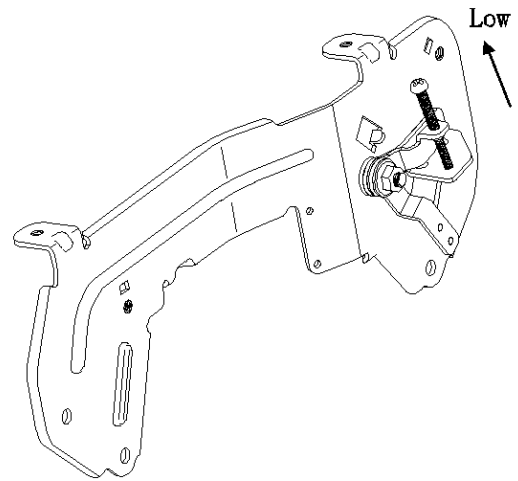

- 2V80FD

Engine

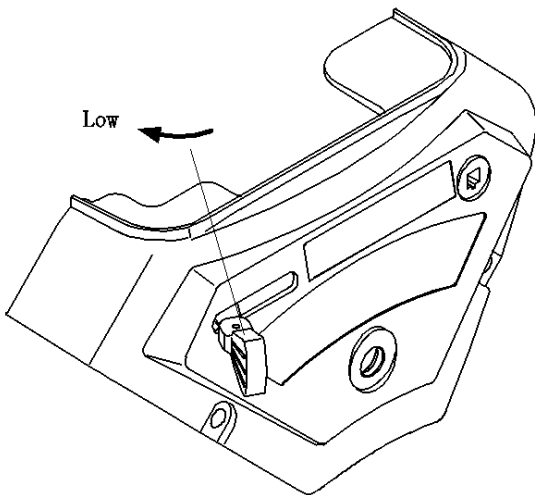

Generator

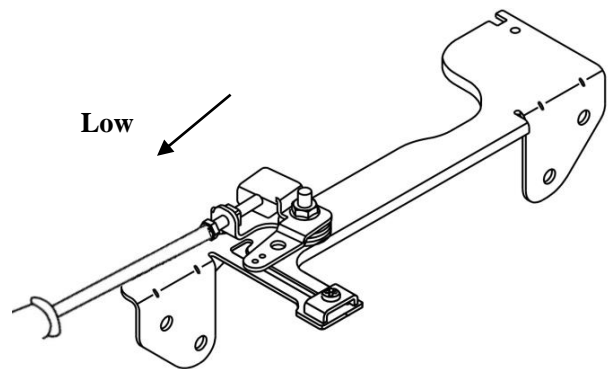

## Stop Engine

---

2) Stop the engine.

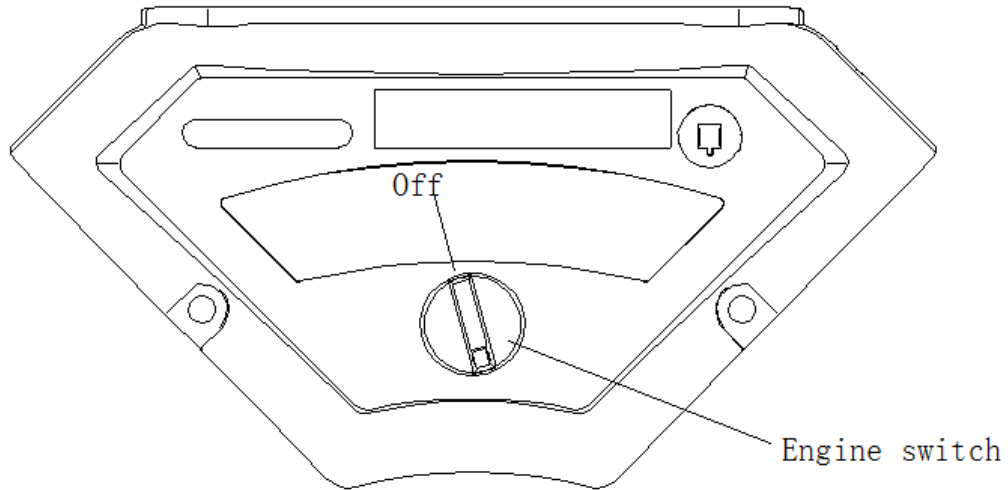

## Engine Maintenance

---

### 7. Maintenance

#### Maintenance schedule

| Periodical maintenance schedule |                  | Every time        | 20 hours or the first month | 50 hours or every 3 month | 100 hours or every 6 month | 300 hours or every year |
|---------------------------------|------------------|-------------------|-----------------------------|---------------------------|----------------------------|-------------------------|
| Engine oil                      | Oil level        | ○                 |                             |                           |                            |                         |
|                                 | Replace          |                   | ○                           |                           | ○                          |                         |
| Fine oil filter                 | Replace          |                   |                             |                           |                            | ○(2) or 200 hours       |
| Air cleaner                     | Check            | ○                 |                             |                           |                            |                         |
|                                 | Clean            |                   |                             | ○(1)                      |                            |                         |
|                                 | Replace          |                   |                             |                           |                            | ○(3)                    |
| Fuel filter                     | Replace          |                   |                             |                           |                            | ○(1)                    |
| Electrolyte level of battery    | Check            | ○                 |                             |                           |                            |                         |
| Spark plug                      | Check & Regulate |                   |                             |                           | ○(2)                       |                         |
|                                 | Replace          |                   |                             |                           |                            | ○                       |
| Valve gap                       | Check & Regulate |                   |                             |                           |                            | ○(2)                    |
| Fuel pipe                       | Replace          | Every 2 years (2) |                             |                           |                            |                         |

○ Maintenance caution

(1) Maintain the engine more frequently in use of dusty area.

(2) The maintenance should be performed by your after-service facilitator unless you have proper tools and specialized technique.

(3) Only replace element.

#### Carburetor Modification for High Altitude Operation

At high altitude, the standard carburetor air-fuel mixture will be too rich. Performance will decrease, and fuel consumption will increase. A very rich mixture will also foul the spark plug and cause hard starting. Operation at an altitude that differs from that at which this engine was certified, for extended periods of time, may increase emissions.

High altitude performance can be improved by specific modifications to the carburetor. If you always operate your engine at altitudes above 5,000 feet (1,500 meters), have your servicing dealer perform this carburetor modification. This engine, when operated at high altitude with the carburetor modifications for high altitude use, will meet each emission standard throughout its useful life.

## Engine Maintenance

---

### Replace oil in crankcase

**After warming up the engine, it is easy to drain the engine oil to ensure the engine oil is rapidly drained out.**

- 1) Place a container under the engine for containing used oil.. Then, remove the oil ruler and loosen the draining screw and washer,.
- 2) After drainage of used oil, reinstall the draining screw and washer and tighten them.

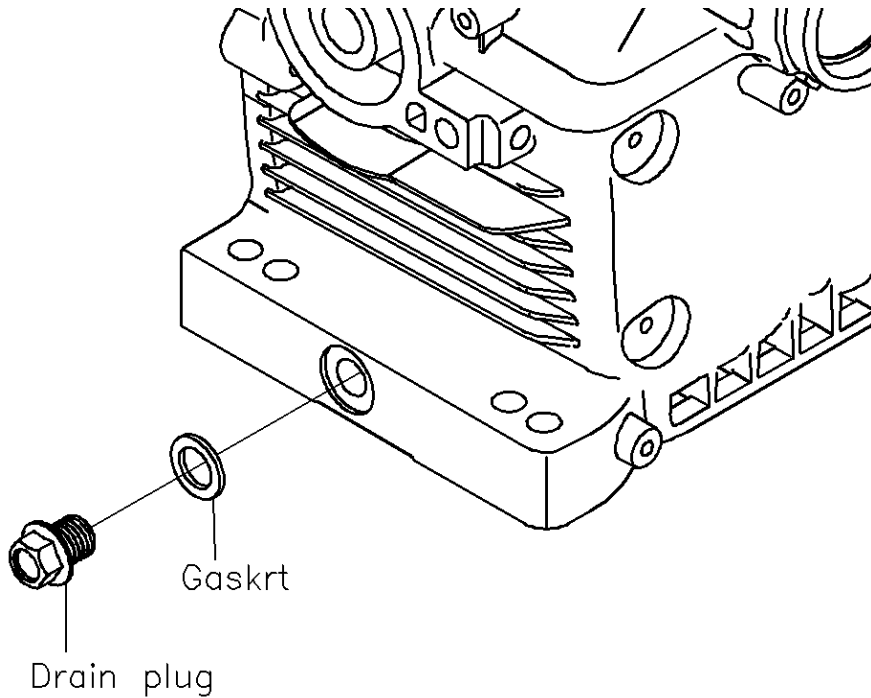

In view of environmental protection, please take a proper way to dispose the waste oil. It is recommended to send the waste oil to the local service station or recycle center. Never throw waste oil barrel to refuse tip, dump the waste oil on ground or in ditches.

- 3) Place the engine in level position, refill recommended oil to the top line.

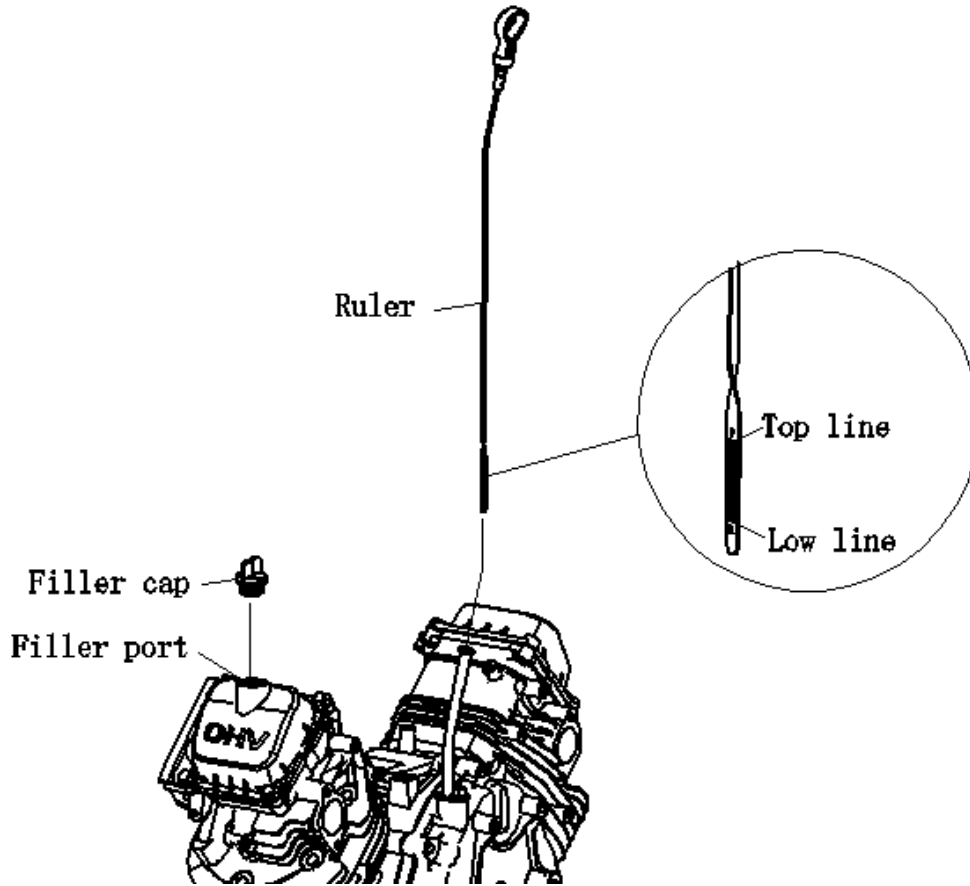

The filling capacity of the engine:

Not replace fine oil filter: **1.8L**

LC2V80FD: **1.6L**

Replace fine oil filter: **2.0L**

LC2V80FD: **1.8L**

- 4) Reinstall the oil ruler and tighten filler cap.

Recommended engine oil:

Engine oil for 4-stroke engine:

API classification: SE、SF or equivalent to SG, SAE 10W-30.

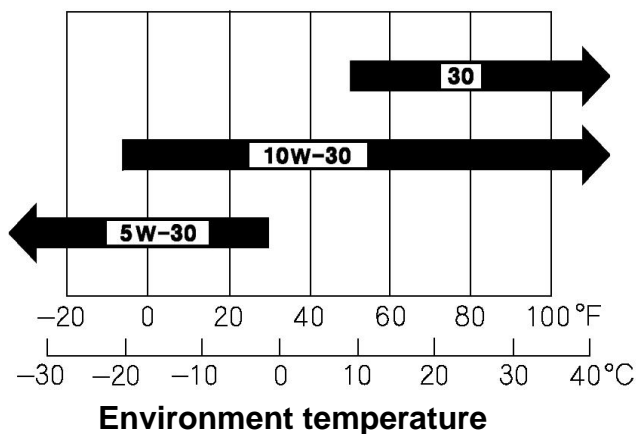

## Engine Maintenance

If the range of temperature change in your area is limited in the above chart, this oil grade can be selected according to it.

### Maintain air cleaner

If the air cleaner is dirty, it affects air inlet, the power of engine reduced. If the running place is dust, maintenance must be done more frequently than that shown in maintenance schedule,..

#### Caution

In the case of no element or element damaged, the dust will be sucked into the engine and result in rapid wear of the engine.

### Double-element air cleaner

- 1) Loosen the clip and remove the air cleaner cover.
- 2) Take out the element.  
Check the elements and replace if necessary.
- 3) Clean air cleaner bracket and cover. Prevent dust from sucking into the carburetor along the inlet pipe.
- 4) Assemble the element..
- 5) Install the cover and tighten the cli

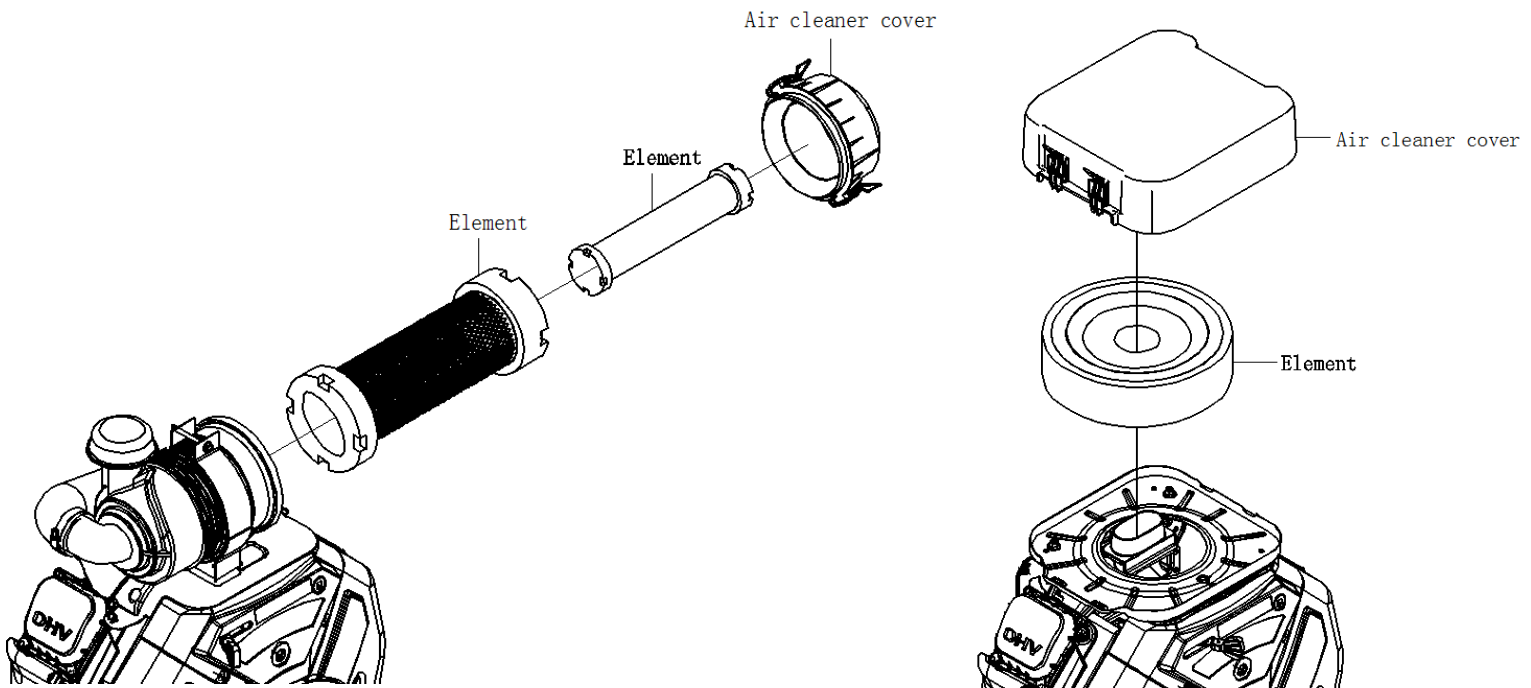

### Spark plug

It is recommended to use spark plug, **RC12YC** or equivalent one.

**Caution**

Spark plug of incorrect type may damage the engine.

- 1) Remove the spark plug cap, Clean dust around the spark plug.
- 2) Unscrew the spark plug with a special socket wrench.

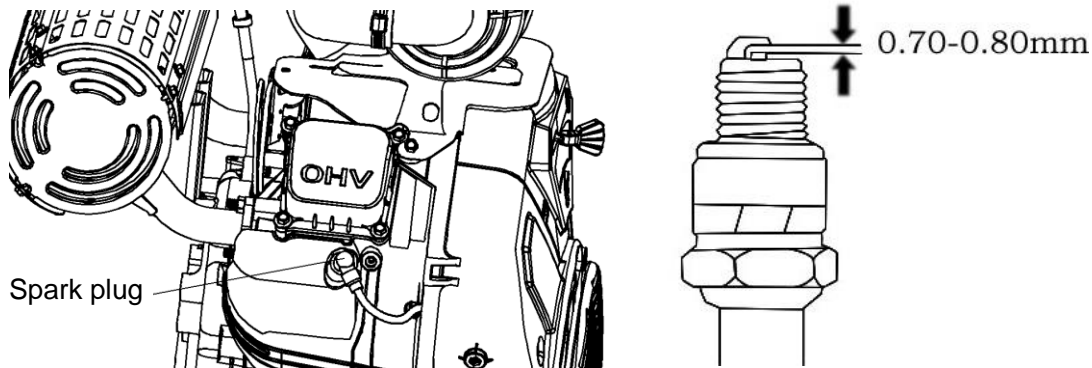

- 3) Check spark plug. If the electrode has damaged, or isolator has broken, replace the spark plug. The clearance of the spark plug electrode should be 0.70-0.80mm. Adjust the side electrode, if necessary.
- 4) Screw the spark plug with hand carefully to avoid damaging the thread on the head.
- 5) When the spark plug is in position, tighten the spark plug with the special socket wrench and depress the washer.  
If install the used spark plug, after depressing the washer, retighten it 1/8-1/4 turn.
- 6) Reinstall the spark plug cap.

### Regulate idle speed

1. Start the engine outdoor, warm up it for a while.
2. Put the regulation lever to "low" position.
3. Regulate the idle speed with a special tool, make idle speed within the range:

Standard idle speed:  $1800 \pm 150$ rpm.

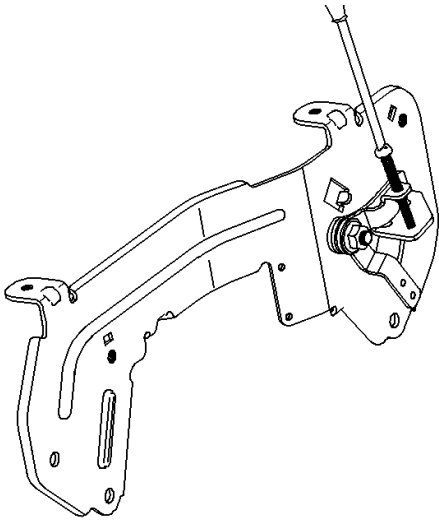

2V90FD speed support plate body

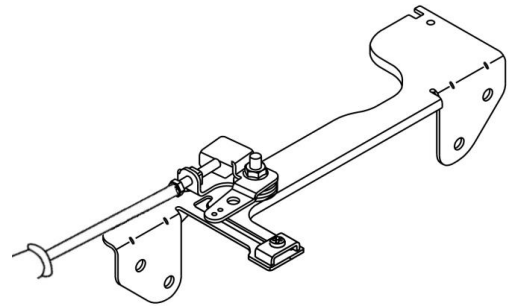

2V80FD speed support plate body

### Generator of digital turn regulating

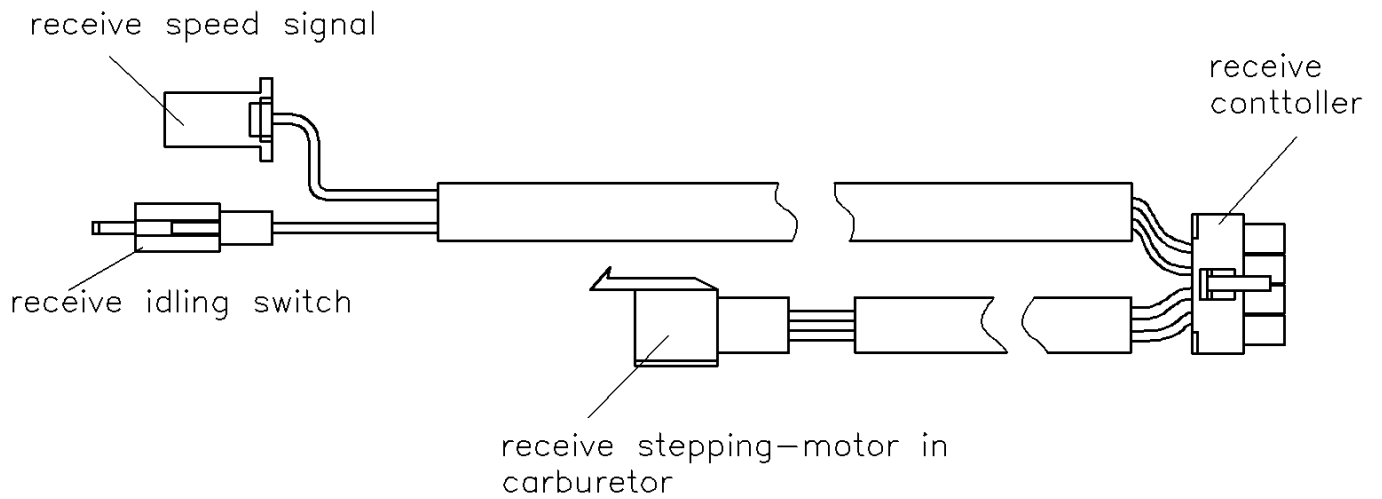

Connect idle switch, after that the engine can get speeding of idling

### 8. Engine storage

After the engine stalling, do not clean the engine till it cools for over half an hour. Clean all surfaces of the engine and mend the damaged paint film, apply antirust oil on the rusting area.

#### Caution

Do not rinse the engine with high pressure water, because the water may enter the air cleaner and the muffler, even enter the cylinder along the inlet line, thus rust may occur. Do not clean the engine till it is cool, because the water splashed on the hot engine is harmful to the engine.

- 1) Place a container under the carburetor (under overflow pipe).
- 2) Unscrew the draining screw of the carburetor, drain the fuel in the carburetor from the overflow pipe to the container. After finishing that, tighten the draining screw.

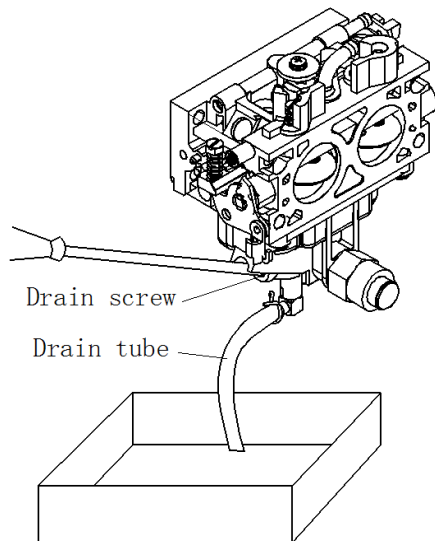

- 3) When using the engine again, replace oil.
- 4) Remove two spark plugs.
- 5) Fill 5lm-10lm oil in the head.
- 6) Rotate the engine in several turns to
- 7) scatter the oil in the head.
- 8) Reinstall the spark plug.
- 9) Rotate the engine slowly till a drag is felt. In such case, all valves are closed to prevent the humidity from air.
- 10) Cover the engine with a dust cap, and place it in dry and ventilating area.
- 11) In storage, the battery is charged every one month, it will prolong the service life of the battery.

**⚠ WARNING**

- The length of time that gasoline can be left in your fuel tank and carburetor without causing functional problems will vary with such factors as gasoline blend, your storage temperatures, and whether the fuel tank is partially or completely filled. The air in a partially filled fuel tank promotes fuel deterioration. Very warm storage temperatures accelerate fuel deterioration. Gasoline will oxidize and deteriorate in storage. Deteriorated gasoline will cause hard starting, and it leaves gum deposits that clog the fuel system. As a result, If the engine is not used for more than one month, the fuel oil shall be drained thoroughly to prevent from deterioration of the fuel in fuel system and carburetor.
- The failures of fuel system or engine performance arising from improper storage are beyond the scope of the warranty.

## 9. Troubleshoot

### 1) Difficult to start

| Phenomena                      |                        |                        |                              | Causes   | Elimination                       |                           |
|--------------------------------|------------------------|------------------------|------------------------------|--|-----------------------------------|---------------------------|
| Cylinder Pressure normal       | Spark plug normal      | Fuel system abnormal   | Fuel line blocked            | No fuel, or fuel cock off                      | Fill fuel, turn on fuel cock      |                           |
|                                |                        |                        |                              | Vent on fuel tank cap blocked                  | Unblock                           |                           |
|                                |                        |                        |                              | Fuel cock blocked                              | Clean                             |                           |
|                                |                        |                        |                              | Orifice improperly regulated or blocked        | Regulate, clean, blow off         |                           |
|                                |                        |                        | Needle valve or float jammed | Repair or replace                              |                                   |                           |
|                                |                        |                        | Fuel line unblocked          | Dirt fuel or deterioration                     | Replace fuel and clean carburetor |                           |
|                                |                        |                        |                              | Fuel mixed with water                          | Replace fuel and clean carburetor |                           |
|                                |                        |                        |                              | Exceeded fuel in cylinder                      | Drain fuel and dry spark plug     |                           |
|                                | Fuel grade not correct | Fill specified fuel    |                              |  |                                   |                           |
|                                | Fuel system normal     | Spark normal           | Spark Plug poor              | carbonized, electrode dirt                     | Clean carbonized dirt             |                           |
|                                |                        |                        |                              | Isolator damaged                               | Replace spark plug                |                           |
|                                |                        |                        |                              | Electrode burnt out                            | Replace spark plug                |                           |
|                                |                        |                        |                              | Improper spark plug clearance                  | Regulate clearance                |                           |
|                                |                        |                        |                              | Spark plug normal                              | No spark                          | High tension wire damaged |
| Ignition coil damaged          |                        |                        |                              |  |                                   | Replace high tension coil |
| Magnetic intensity inefficient | Magnetize or replace   |                        |                              |  |                                   |                           |
| Cylinder Pressure abnormal     | Fuel system normal     | Ignition System normal | Spark plug normal            | Piston ring worn out or broken                 | Replace                           |                           |
|                                |                        |                        |                              | Piston ring agglutinated                       | Clean carbonized dirt             |                           |
|                                |                        |                        |                              | Spark plug without washer or tightened loosely | Fit washer or tighten             |                           |
|                                |                        |                        |                              | Leakage between head and block                 | Replace cylinder                  |                           |
|                                |                        |                        |                              | Poor air tight at valve                        | Grind or replace                  |                           |

## Troubleshoot

### 2) Inefficient power

| Phenomena  | Causes           |   | Elimination              |
|--|------------------|---|--------------------------|
| Speed increase slowly while accelerating , even decrease or engine stall in severe condition | Ignition system  | Improper timing                         | Replace ignition coil    |
|  | Fuel system      | Air mixed in fuel line                  | Exhaust air              |
|  |                  | Orifice regulated improperly            | Regulate                 |
|  |                  | Needle valve or orifice blocked         | Clean , blow off         |
|  |                  | Fuel cock blocked                       | Clean or replace         |
|  |                  | Carbonized in combustion chamber        | Clean carbonized dirt    |
|  | Inlet system     | Air cleaner block                       | Clean or replace element |
|  |                  | Inlet system leakage                    | Repair or replace        |
|  | Poor compression | Piston , cylinder, piston ring worn out | replace                  |
|  |                  | Leakage between block and head          | Replace gasket           |
|  |                  | Incorrect valve clearance               | Regulate                 |
|  |                  | Valve untight                           | Grind or replace         |

### 3) Sudden stall

| Phenomena           | Causes          |   | Elimination                    |
|---------------------|-----------------|---|--------------------------------|
| Sudden stall at run | Fuel system     | Fuel run out  | Fill fuel, unblock             |
|                     |                 | Carburetor blocked  | Check fuel line, unblock       |
|                     |                 | Oil leaked from carburetor float                                  | Repair float                   |
|                     |                 | Needle valve jammed   | Repair needle valve            |
|                     |                 | Solenoid valve of carburetor damage                               | Change solenoid valve          |
|                     | Ignition system | Spark plug sparked through<br>Carbonized dirt makes short circuit | Replace spark plug             |
|                     |                 | Spark plug electrode dropped off                                  | Replace spark plug             |
|                     |                 | High tension wire dropped off                                     | Repair or replace              |
|                     |                 | Ignition coil broken down   | replace                        |
|                     | Others          | Severely scuffing of cylinder bore or valve dropped off           | Repair or replace damaged part |

## Troubleshoot

---

### 4) Engine overheating

| Phenomena          | Causes   | Elimination  |
|--------------------|--|--|
| Engine overheating | Improper timing  | Replace ignition coil                              |
|                    | Insufficient engine oil  | Fill engine oil                                    |
|                    | Outlet blocked   | Clean outlet                                       |
|                    | Ventilation hood leakage   | Repair damaged place                               |
|                    | Air conduit blocked with foreign thing                             | Clean radiator                                     |
|                    | Cool fan failed  | Reinstall fan                                      |
|                    | Piston ring failed to result in cylinder and crank case flowing by | Replace worn part                                  |
|                    | Engine runs at over speed  | Check regulating system or replace regulating gear |

### 5) Abnormal noise

| Phenomena                    | Causes   | Elimination                          |
|------------------------------|--|--------------------------------------|
| Slap                         | Piston, piston ring worn out                   | Replace worn part                    |
|                              | Connection rod, piston pin, pin hole worn out  | Replace worn part                    |
|                              | Crank worn                                     | Replace or repair                    |
|                              | Piston ring broken                             | Replace piston ring                  |
| Knocking with metallic sound | Exceeded carbonized dirt in combustion chamber | Clean carbonized dirt                |
|                              | Spark plug electrode clearance too small       | Regulate electrode clearance         |
|                              | Severely enriched fuel                         | Check Carburetor                     |
|                              | Improper fuel grade                            | Replace fuel                         |
|                              | Engine overheating                             | Refer to overheat fault column       |
| Abnormal noise               | Regulate valve improperly                      | Regulate valve clearance             |
|                              | Loose connection between flywheel and crank    | Replace connecting key and reinstall |

## 10. Battery (optional)

Please choose the battery, 12V, rated capacity of 36Ah. or more.

### Caution

Never connect the positive and negative electrodes in reverse, otherwise, it will damage the engine and battery severely.

Check the electrolyte level in cell if they are in the position between the top limit line and low limit line. If the electrolyte level is lower the low limit line, screw out the cap and fill distilled water till it rises up to top limit line. All electrolyte level in cells should be almost in the same height.

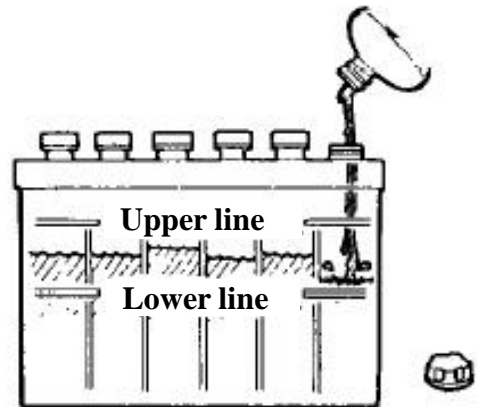

### Warning

- If operate improperly, the battery may explode, thus, hurt may occur to the persons around, therefore, keep the smoke and flame and inflammable things away from the battery.
- the battery will release explosion gas, keep the fire away from it. When charge the battery or use the battery, keep ventilating.

Connect start motor:

Be careful not to connect the terminals in reverse, or short circuit occurs. As usual, connect the positive electrode before do it for negative one.

- 1) Connect positive wire of the battery to the terminal of start relay.
- 2) Connect negative wire of the battery to the screw of engine bracket.
- 3) Connect positive wire of the battery to the positive terminal of the battery.
- 4) Connect negative wire of the battery to the negative terminal of the battery..

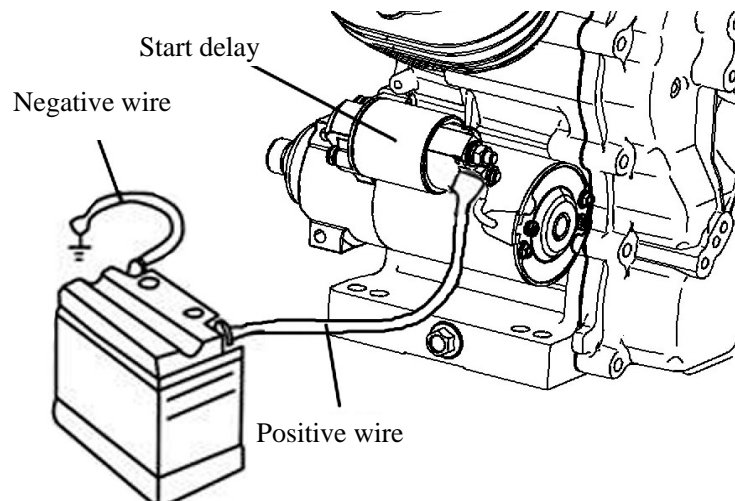

## 11. Engine parameters

| Project                         | LC2V90FD                              |             | LC2V80FD          |             |
|---------------------------------|---------------------------------------|-------------|-------------------|-------------|
| Engine status                   | engine                                | Generator   | engine            | Generator   |
| Engine Type                     | 2-cyl、4-stroke、forced air cooling、OHV |             |                   |             |
| Displacement<br>(bore X stroke) | 999ml (90X78.5mm)                     |             | 764ml (80mmX76mm) |             |
| Rated power<br>(kW/3600rpm)     | 22                                    |             | 18                |             |
| Max torsion(N·m)<br>speed(rpm)  | 70/2800                               |             | 52/2800           |             |
| Fuel rate<br>(g/kW·h)           | ≤374                                  |             |                   |             |
| Idle speed<br>(rpm)             | 1800±150                              |             |                   |             |
| Speed fluctuation ratio         | ≤10%                                  |             |                   |             |
| Compression ratio               | 8.5:1                                 |             | 8.7:1             |             |
| Start mode                      | Powered start                         |             |                   |             |
| Rotation direction              | CCW (face to output side)             |             |                   |             |
| Valve gap (mm)                  | Inlet 0.10~0.15                       |             |                   |             |
|                                 | outlet 0.15~0.20                      |             |                   |             |
| Spark plug                      | RC12YC                                |             |                   |             |
| Plug clearance (mm)             | 0.7~0.8                               |             |                   |             |
| Ignition mode                   | transistor no-contact ignition        |             |                   |             |
| Type of air cleaner             | Double elements                       |             |                   |             |
| Dimension (mm)<br>L×W×H         | 555X567X723                           | 555X567X542 | 507X502X690       | 507X502X500 |
| Net weight (kg)                 | 60                                    | 59          | 50                | 49          |

The power rating of the engine indicated in this document is the net power output tested on a production engine for the engine model and measured in accordance with SAE J1349 at 3,600 rpm (Net Power). Mass production engines may vary from this value.

Actual power output for the engine installed in the final machine will vary depending on numerous factors, including the operating speed of the engine in application, environmental conditions, maintenance, and other variables.

## 12. Wiring diagram

Powered starting engine with oil protection system

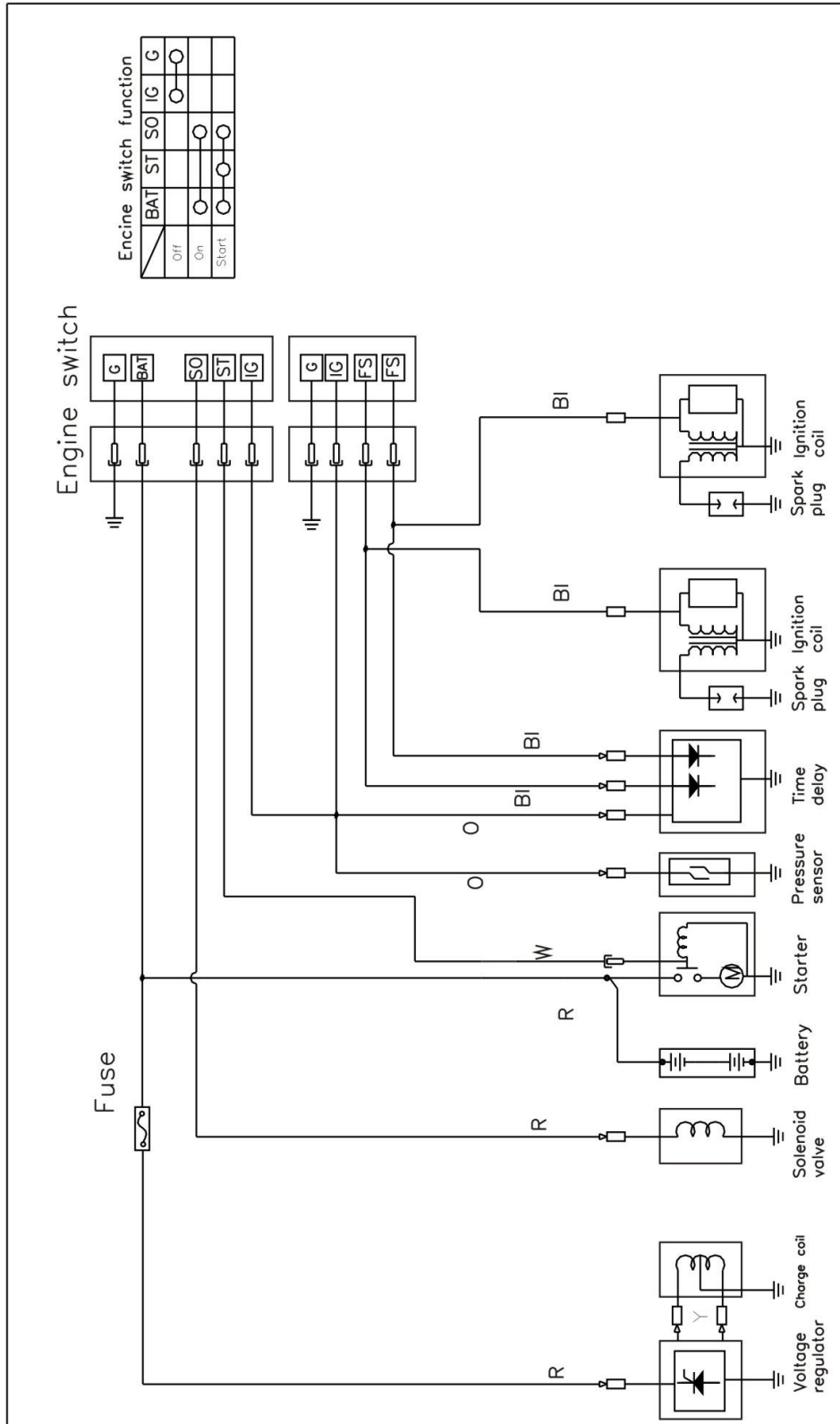

---